

PART SW SW

E CARONDELET IL 62240

Site Address: 011728 LEVEE RD

BLDG # 1
 Style/Stories 1.0 One Story
 Quality/Design C C-Average
 Building Use 0100 Single Fami
 Exterior Wall F Frame
 WALL % 100 100%
 Exterior Wall 1
 WALL 1% 000 N/A
 Crawl Sp. Adj C Crawl
 Slab Adjustment
 Basement
 Combination
 Attic Area
 Heat/AC Adj AC Central Air
 Comb Ht/AC Adj
 Fireplace 03 C-Fireplace
 Extra Fireplace 00 N/A
 Res Fixtures 0008 08 Fixtures
 Garage F Frame Garag
 Integral Garage
 Remodeling Adj 01 No Remodeli
 Actual Year Blt 1959
 Effect Year Blt 1959
 Cond/Desir/Util A Res CDU - A
 Township Multpl 02 TOWNSHIP #0
 Funct. Obs. % 000000
 Economic Obs. % 000000
 Observed Cond % 000000
 Obs. Cond. Code
 Combination A
 Comb A Ht/AC
 Unfin Low/Level
 Full Basement
 # Of Bedrooms 03 Three Bedro
 Sq.Ft.Grd Area 2148

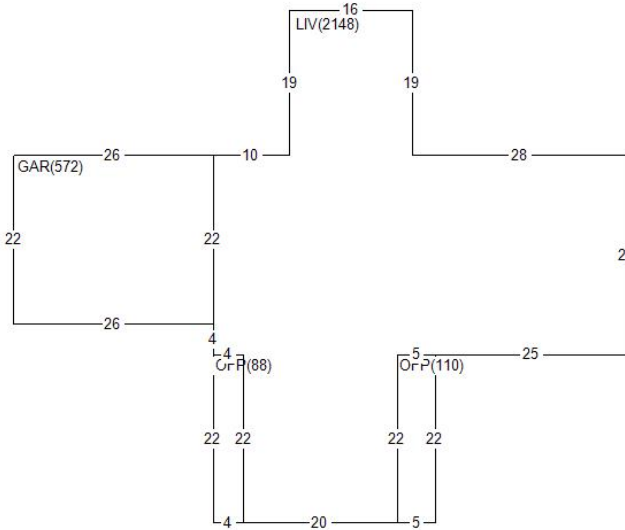

Land Value 25,000
 Misc Value 13,160
 Bldg Value 172,400
 Total Value 210,560
 Value By CAMA

RCN 313,456
 Pct Good 0.5500
 Obsol/Observed 0.0000
 Building Value 172,400

DOCUMENT #	DATE	QS	SALE PRICE
326246	0908	04	
272328	0403	26	

PERMIT NO	TYPE	DATE	AMOUNT
12766	09	0710	

Appraiser KS K. Sondag
 Appr Date 10/26/20
 Use Code 0040 Imp Res
 NBHD 406.10 1-5 1.0 40/NEW
 L100 M100 B202

AREA	FLAT	EFF%	E/AREA	ACT%	A/AREA	EA/AA	HEATED
CRWL	744	1.00	744	1.00	744	744	
CONDR	260	1.00	260	1.00	260	260	
OFF	198	1.00	198	1.00	198	198	
GAR	572	1.00	572	1.00	572	572	
LIV	2148	1.00	2148	1.00	2148	2148	2148

MISC BLDG CODE	DESC	LENGTH	WIDTH	UNITS	ADJ PRICE	EYB DT PCT	ADJUSTMENT	VALUE
1 1 OFF	Open Frame Porch	4.00	22.00	88.00	28.43	2011 A 5.00	1.00	2,380
2 1 OFF	Open Frame Porch	5.00	22.00	110.00	26.28	2011 A 5.00	1.00	2,750
3 1 CONDR	Concrete Drivewa	10.00	26.00	260.00	3.65	2011 A 5.00	1.00	900
4 1 BRVEN	Brick Veneer	.00	.00	512.00	14.65	2011 A 5.00	1.00	7,130

LAND LUSE DESC	ZONING	UNITS TP	PRICE	ADJUSTMENT	CODE/FACTOR	VALUE
1 CE County Road Cat.	MA1	1.00 R	25000.00	.00	.00 TW 1.00	25,000