

TAX LOT 15

ST LOUIS MO 63131
Site Address: 000442 BIXBY RD

BLDG # 1
 Style/Stories 1.0 One Story
 Quality/Design C C-Average
 Building Use 0100 Single Fami
 Exterior Wall F Frame
 WALL % 100 100%
 Exterior Wall 1
 WALL 1% 000 N/A
 Crawl Sp. Adj C Crawl
 Slab Adjustment
 Basement
 Combination
 Attic Area
 Heat/AC Adj AC Central Air
 Comb Ht/AC Adj
 Fireplace
 Extra Fireplace 00 N/A
 Res Fixtures 0008 08 Fixtures
 Garage
 Integral Garage
 Remodeling Adj 02 Slight Upda
 Actual Year Blt 1957
 Effect Year Blt 1957
 Cond/Desir/Util A
 Township Multpl 02 TOWNSHIP #0
 Funct. Obs. % 000000
 Economic Obs. % 000000
 Observed Cond % 000000
 Obs. Cond. Code
 Combination A
 Comb A Ht/AC
 Unfin Low/Level
 Full Basement
 # Of Bedrooms 03 Three Bedro
 Sq.Ft.Grd Area 1864

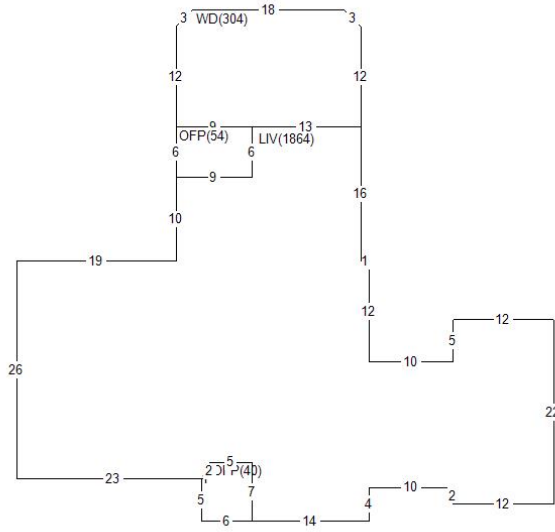

Land Value 32,000
 Misc Value 46,390
 Bldg Value 137,180
 Total Value 215,570
 Value By CAMA

RCN 249,409
 Pct Good 0.5500
 Obsol/Observed 0.0000
 Building Value 137,180

DOCUMENT #	DATE	QS	SALE PRICE
396065	0518	U	
396064	0518	U	230,000
309800	1006	04	
PERMIT NO	TYPE	DATE	AMOUNT
9972	00	0601	
10034	05	1000	
9972	04	0800	
Appraiser KS K. Sondag			
Appr Date 10/26/20			
Use Code 0011 Imp. Farm			
NBHD	406.10	1-5 1.0	40/NEW L100 M100 B202

AREA	FLAT	EFF%	E/AREA	ACT%	A/AREA	EA/AA	HEATED
OFPP	94	1.00	94	1.00	94	94	
WD	304	1.00	304	1.00	304	304	
LIV	1864	1.00	1864	1.00	1864	1864	1864
CRWL	712	1.00	712	1.00	712	712	

MISC BLDG CODE	DESC	LENGTH	WIDTH	UNITS	ADJ PRICE	EYB DT PCT	ADJUSTMENT	VALUE
1 1 OFPP	Open Frame Porch	6.00	9.00	54.00	34.75	1957 A 45.00	1.00	1,030
2 1 OFPP	Open Frame Porch	.00	.00	40.00	40.00	1957 A 45.00	1.00	880
3 1 WD	Wood Deck	.00	.00	304.00	19.35	2000 A 13.00	1.00	5,120
4 1 GARF	Garage Frame	30.00	40.00	1200.00	19.22	2001 A 12.00	1.00	20,300
5 1 PTO	Concrete Patio	14.00	11.00	154.00	3.65	2017 A 2.00	1.00	550
6 1 F-SALV	Salv Farm Buildi	.00	.00	1.00	300.00	00 FD 0.00	1.00	300
LAND LUSE DESC	ZONING	UNITS	TP	PRICE	ADJUSTMENT	CODE/FACTOR	ADJUSTMENT	VALUE
1 CE	County Road Cat.	2.50	R	12800.00	.00	.00	.00 TW 1.00	32,000

Req By: KRIS_K
NOT CR FARMS LLC
41 PORTLAND DRIVE

			ST LOUIS			MO 63131					
			Site Address: 000442			BIXBY			RD		
MISC	BLDG CODE	DESC	LENGTH	WIDTH	UNITS	ADJ PRICE	EYB DT	PCT	ADJUSTMENT	VALUE	
7	2 F-PS4C12	Pole Shd 4 Sde C	117.00	54.00	6318.00	10.46	1978 F3	85.00	1.00	9,910	
8	3 F-LTW	Lean-to Wood	62.00	21.00	1302.00	8.37	1970 F3	85.00	1.00	1,640	
9	4 F-PS4C12	Pole Shd 4 Sde C	62.00	42.00	2604.00	12.05	1970 F3	85.00	1.00	4,710	
10	5 F-FRSHED08	Frame Shed 8'	25.00	18.00	450.00	25.23	1960 F3	85.00	1.00	1,700	
11	9 F-PSCFL	Pole Shd Conc Fl	25.00	18.00	450.00	3.65	1960 F3	85.00	1.00	250	