

TAX LOT 6B

E CARONDELET IL 62240
Site Address: 001608 DD RD

BLDG # 1
 Style/Stories 1.0 One Story
 Quality/Design C C-Average
 Building Use 0100 Single Fami
 Exterior Wall M Masonry 1.0
 WALL % 100 100%
 Exterior Wall 1
 WALL 1% 000 N/A
 Crawl Sp. Adj C Crawl
 Slab Adjustment
 Basement
 Combination
 Attic Area
 Heat/AC Adj AC Central Air
 Comb Ht/AC Adj
 Fireplace 00 N/A
 Extra Fireplace 00 N/A
 Res Fixtures 0006 06 Fixtures
 Garage M Masonry Gar
 Integral Garage
 Remodeling Adj 04 1/2 - 3/4 U
 Actual Year Blt 1967
 Effect Year Blt 1967
 Cond/Desir/Util A Res CDU - A
 Township Multpl 03 TOWNSHIP #0
 Funct. Obs. % 000000
 Economic Obs. % 000000
 Observed Cond % 000000
 Obs. Cond. Code
 Combination A
 Comb A Ht/AC
 Unfin Low/Level
 Full Basement
 # Of Bedrooms 03 Three Bedro
 Sq.Ft.Grđ Area 1526

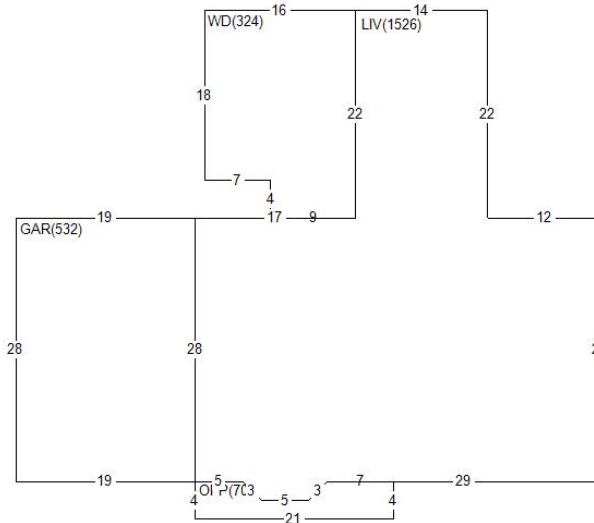

Land Value 5,640
 Misc Value 9,730
 Bldg Value 109,060
 Total Value 124,430
 Value By CAMA
 RCN 194,755
 Pct Good 0.5600
 Obsol/Observed 0.0000
 Building Value 109,060

DOCUMENT #	DATE	QS	SALE PRICE
360783	1112	07	226,000
355837	0512	U	
	0294	07	

PERMIT NO	TYPE	DATE	AMOUNT
9738	00	0200	
7778	09	0694	
0	99	0690	

Appraiser KS K. Sondag
 Apr Date 10/27/20
 Use Code 0040 Imp Res
 NBHD 1900.10 FLD PLN 60-NEW
 L100 M100 B154

AREA	FLAT	EFF%	E/AREA	ACT%	A/AREA	EA/AA	HEATED
CRWL	308	1.00	308	1.00	308	308	
SHED	192	1.00	192	1.00	192	192	
GAR	532	1.00	532	1.00	532	532	
OFB	70	1.00	70	1.00	70	70	
WD	324	1.00	324	1.00	324	324	
LIV	1526	1.00	1526	1.00	1526	1526	1526

MISC BLDG CODE	DESC	LENGTH	WIDTH	UNITS	ADJ PRICE	EYB DT	PCT	ADJUSTMENT	VALUE
1 1 OFP	Open Frame Porch	.00	.00	70.00	30.94	1967 A	44.00	1.00	1,210
2 1 SHED	Frame Shed	16.00	12.00	192.00	26.36	1975 A	37.00	1.00	3,190
3 1 WD	Wood Deck	.00	.00	324.00	19.35	1997 A	15.00	1.00	5,330

LAND LUSE DESC	ZONING	UNITS TP	PRICE	ADJUSTMENT	CODE/FACTOR	VALUE
1 CK County Road Cat.	MA1	1.88 R	3000.00	.00	.00 TW 1.00	5,640