

Req By: KRIS_K
KEVIN & JODI A STUMPF
7883 NEVOIS LANE

TAX LOT 6B

E CARONDELET IL 62240
Site Address: 001608 DD RD

BLDG # 1
 Style/Stories 1.0 One Story
 Quality/Design C C-Average
 Building Use 0100 Single Fami
 Exterior Wall M Masonry 1.0
 WALL % 100 100%
 Exterior Wall 1
 WALL 1% 000 N/A
 Crawl Sp. Adj C Crawl
 Slab Adjustment
 Basement
 Combination
 Attic Area
 Heat/AC Adj AC Central Air
 Comb Ht/AC Adj
 Fireplace 00 N/A
 Extra Fireplace 00 N/A
 Res Fixtures 0006 06 Fixtures
 Garage M Masonry Gar
 Integral Garage
 Remodeling Adj 04 1/2 - 3/4 U
 Actual Year Blt 1967
 Effect Year Blt 1967
 Cond/Desir/Util A Res CDU - A
 Township Multpl 03 TOWNSHIP #0
 Funct. Obs. % 000000
 Economic Obs. % 000000
 Observed Cond % 000000
 Obs. Cond. Code
 Combination A
 Comb A Ht/AC
 Unfin Low/Level
 Full Basement
 # Of Bedrooms 03 Three Bedro
 Sq.Ft.Grđ Area 1526

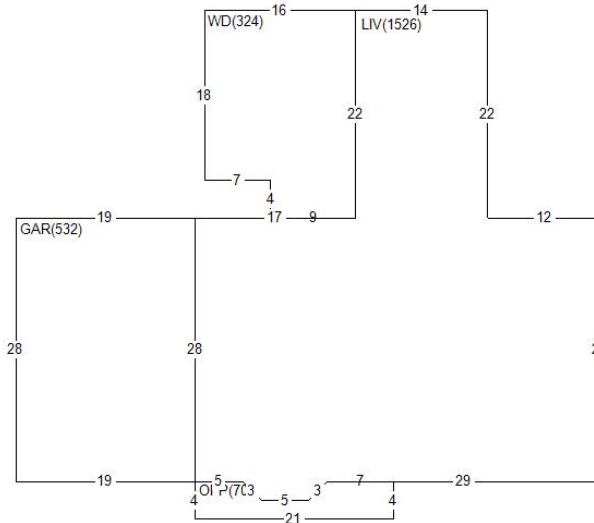

Land Value 5,640
 Misc Value 9,600
 Bldg Value 118,240
 Total Value 133,480
 Value By CAMA

RCN 214,989
 Pct Good 0.5500
 Obsol/Observed 0.0000
 Building Value 118,240

DOCUMENT #	DATE QS	SALE PRICE
360783	1112 07	226,000
355837	0512 U	
	0294 07	

PERMIT NO	TYPE	DATE	AMOUNT
9738	00	0200	
7778	09	0694	
0	99	0690	

Appraiser KS K. Sondag
 Apr Date 10/27/20
 Use Code 0040 Imp Res

AREA	FLAT	EFF%	E/AREA	ACT%	A/AREA	EA/AA	HEATED	NBHD	1900.10	FLD	PLN	60-NEW
CRWL	308	1.00	308	1.00	308	308						L100 M100 B170
SHED	192	1.00	192	1.00	192	192						
GAR	532	1.00	532	1.00	532	532						
OFB	70	1.00	70	1.00	70	70						
WD	324	1.00	324	1.00	324	324						
LIV	1526	1.00	1526	1.00	1526	1526	1526					

MISC BLDG CODE	DESC	LENGTH	WIDTH	UNITS	ADJ PRICE	EYB DT	PCT	ADJUSTMENT	VALUE
1 1 OFP	Open Frame Porch	.00	.00	70.00	30.94	1967 A	45.00	1.00	1,190
2 1 SHED	Frame Shed	16.00	12.00	192.00	26.36	1975 A	38.00	1.00	3,140
3 1 WD	Wood Deck	.00	.00	324.00	19.35	1997 A	16.00	1.00	5,270

LAND LUSE DESC	ZONING	UNITS TP	PRICE	ADJUSTMENT	CODE/FACTOR	VALUE
1 CK County Road Cat.	MA1	1.88 R	3000.00	.00	.00 TW 1.00	5,640