

PART LOT 3

COLUMBIA IL 62236

Site Address: 010912 LEVEE RD

BLDG # 1
 Style/Stories SPL Split-Level
 Quality/Design C C-Average
 Building Use 0100 Single Fami
 Exterior Wall F Frame SPL
 WALL % 100 100%
 Exterior Wall 1
 WALL 1% 000 N/A
 Crawl Sp. Adj C Crawl
 Slab Adjustment
 Basement
 Combination M1 Masonry/1.0
 Attic Area
 Heat/AC Adj AC Central Air
 Comb Ht/AC Adj AC1 Cent AC Cmb
 Fireplace 03 C-Fireplace
 Extra Fireplace 00 N/A
 Res Fixtures 0010 10 Fixtures
 Garage M Masonry Gar
 Integral Garage
 Remodeling Adj 01 No Remodeli
 Actual Year Blt 1962
 Effect Year Blt 1962
 Cond/Desir/Util A Res CDU - A
 Township Multpl 03 TOWNSHIP #0
 Funct. Obs. % 000000
 Economic Obs. % 000010
 Observed Cond % 000000
 Obs. Cond. Code
 Combination A
 Comb A Ht/AC
 Unfin Low/Level
 Full Basement
 # Of Bedrooms 03 Three Bedro
 Sq.Ft.Grđ Area 1363

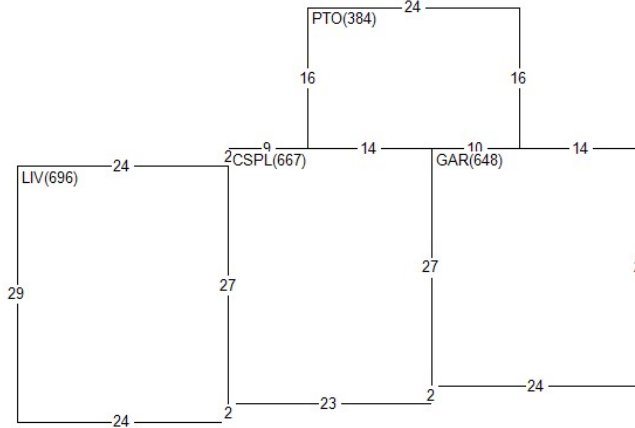

Land Value 3,000
 Misc Value 27,180
 Bldg Value 115,260
 Total Value 145,440
 Value By CAMA

RCN 256,134
 Pct Good 0.5500
 Obsol/Observed 0.1000
 Building Value 115,260

DOCUMENT # DATE QS SALE PRICE
 0368 Q

PERMIT NO TYPE DATE AMOUNT
 14501 00 0118
 14501 31 1117

Appraiser KK K. Kenned
 Appr Date 01/21/22
 Use Code 0040 Imp Res
 NBHD 1900.10 FLD PLN 60-NEW
 L100 M100 B170

AREA	FLAT	EFF% E/AREA	ACT% A/AREA	EA/AA HEATED
CONDR	630	1.00	630 1.00	630 630
CRWL	48	1.00	48 1.00	48 48
SHED	224	1.00	224 1.00	224 224
PTO	384	1.00	384 1.00	384 384
GAR	648	1.00	648 1.00	648 648
CSPL	667	1.00	667 1.00	667 667
LIV	696	1.00	696 1.00	696 696

MISC BLDG CODE	DESC	LENGTH	WIDTH	UNITS	ADJ PRICE	EYB DT PCT	ADJUSTMENT	VALUE
1 1 BRVEN	Brick Veneer	.00	.00	396.00	14.65	1962 A 45.00	1.00	3,190
3 1 CONDR	Concrete Drivewa	35.00	18.00	630.00	3.65	1962 A 45.00	1.00	1,270
4 1 SHED	Frame Shed	16.00	14.00	224.00	26.26	2005 A 11.00	1.00	5,240
5 1 PTO	Concrete Patio	16.00	24.00	384.00	3.65	2012 A 5.00	1.00	1,330
6 1 OFP	Open Frame Porch	12.00	12.00	144.00	24.29	2017 A 2.00	1.00	3,430
7 1 CONDR	Concrete Drivewa	15.00	15.00	225.00	3.65	2017 A 2.00	1.00	810
LAND LUSE DESC	ZONING	UNITS TP	PRICE	ADJUSTMENT	CODE/FACTOR	ADJUSTMENT	VALUE	
1 CK County Road Cat.	MAL	1.00 R	3000.00	.00	.00	.00 TW 1.00	3,000	

Req By: DAWN
HERBERT & DONNA WILDE
10912 LEVEE ROAD

MISC BLDG CODE	DESC	Site Address:	COLUMBIA	LEVEE	IL 62236	RD	ADJ PRICE	EYB DT PCT	ADJUSTMENT	VALUE
8 1 PS4C14	Pole Shd 4 Sde C	010912	010912	1200.00			15.04	2017 20 34.00	1.00	11,910
		LENGTH	WIDTH	UNITS						
		40.00	30.00							