

Req By: KRIS\_K  
HARRY A ROBERTS  
166 GLENDALE DR

PART S 1/2 NW

COLUMBIA IL 62236

Site Address: 009613 GILMORE LAKE RD

BLDG # 1  
 Style/Stories 1.5 1 1/2 Story  
 Quality/Design U U-Unsound  
 Building Use 0100 Single Fami  
 Exterior Wall M Masonry 1.5  
 WALL % 070 070%  
 Exterior Wall 1 F Frame  
 WALL 1% 030 030%  
 Crawl Sp. Adj  
 Slab Adjustment  
 Basement  
 Combination  
 Attic Area  
 Heat/AC Adj  
 Comb Ht/AC Adj  
 Fireplace 00 N/A  
 Extra Fireplace 00 N/A  
 Res Fixtures 0008 08 Fixtures  
 Garage  
 Integral Garage  
 Remodeling Adj 01 No Remodeli  
 Actual Year Blt 1929  
 Effect Year Blt 1929  
 Cond/Desir/Util U Res CDU - U  
 Township Multpl 05 TOWNSHIP #0  
 Funct. Obs. % 000000  
 Economic Obs. % 000000  
 Observed Cond % 000000  
 Obs. Cond. Code  
 Combination A  
 Comb A Ht/AC  
 Unfin Low/Level  
 Full Basement F Full Baseme  
 # Of Bedrooms 02 Two Bedroom  
 Sq.Ft.Grđ Area 938

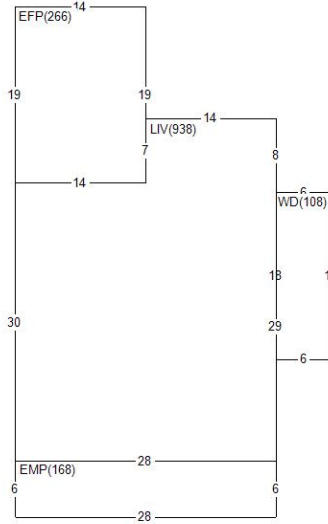

Land Value 0  
 Misc Value 27,310  
 Bldg Value 2,510  
 Total Value 29,820  
 Value By CAMA  
 RCN 25,084  
 Pct Good 0.1000  
 Obsol/Observed 0.0000  
 Building Value 2,510

DOCUMENT #	DATE	QS	SALE PRICE
	0399	U	140,000
	0996	U	24,000
	0595	U	30,000
PERMIT NO	TYPE	DATE	AMOUNT
NOR	99	1098	
6192	31	0590	

Appraiser JB J. Brown  
 Appr Date 10/19/20  
 Use Code 0011 Imp. Farm  
 NBHD 406.16 1-5 1.5 PR/1940  
 L100 M100 B090

AREA	FLAT	EFF%	E/AREA	ACT%	A/AREA	EA/AA	HEATED
WD	108	1.00	108	1.00	108	108	
EMP	168	1.00	168	1.00	168	168	
EFP	266	1.00	266	1.00	266	266	
LIV	938	1.00	938	1.00	938	938	938
PTO	392	1.00	392	1.00	392	392	
GAR	288	1.00	288	1.00	288	288	
SHED	64	1.00	64	1.00	64	64	

MISC BLDG CODE	DESC	LENGTH	WIDTH	UNITS	ADJ PRICE	EYB DT	PCT	ADJUSTMENT	VALUE
1	1 EFP	19.00	14.00	266.00	38.17	1929 P	60.00	1.00	4,060
2	1 EMP	6.00	28.00	168.00	47.57	1929 P	60.00	1.00	3,200
3	1 GARF	12.00	24.00	288.00	19.24	1940 A	45.00	1.00	3,050
4	1 SHED	8.00	8.00	64.00	26.79	1940 A	45.00	1.00	940
5	1 WD	6.00	18.00	108.00	9.68	1980 P	47.00	.50	550
6	1 PTO	14.00	28.00	392.00	3.65	1995 P	32.00	1.00	970

Req By: KRIS\_K  
 HARRY A ROBERTS  
 166 GLENDALE DR

			COLUMBIA		IL 62236						
			Site Address: 009613		GILMORE LAKE		RD				
MISC	BLDG CODE	DESC	LENGTH	WIDTH	UNITS	ADJ PRICE	EYB	DT	PCT	ADJUSTMENT	VALUE
7	1 F-SALV	Salv Farm Buildi	.00	.00	1.00	300.00	00	FD	0.00	1.00	300
8	2 F-SALV	Salv Farm Buildi	.00	.00	1.00	300.00	00	FD	0.00	1.00	300
9	3 F-FRSHED14	Frame Shed 14'	28.00	24.00	672.00	13.10	1932	F3	85.00	.50	1,320
10	4 F-SALV	Salv Farm Buildi	.00	.00	1.00	300.00	00	FD	0.00	1.00	300
11	5 F-SALV	Salv Farm Buildi	.00	.00	1.00	300.00	00	FD	0.00	1.00	300
12	6 F-PS4C14	Pole Shd 4 Sde C	60.00	40.00	2400.00	9.74	1966	F3	85.00	.75	3,510
13	6 F-PSCFL	Pole Shd Conc Fl	21.00	21.00	441.00	3.65	1966	F3	85.00	1.00	240
14	7 F-LTP	Lean-to Pole	60.00	20.00	1200.00	4.60	1966	F3	85.00	.75	830
15	8 F-CONC	Farm Concrete	32.00	16.00	512.00	1.83	1960	F3	85.00	.50	140
16	9 F-SALV	Salv Farm Buildi	.00	.00	1.00	300.00	00	FD	0.00	1.00	300
17	10 F-SALV	Salv Farm Buildi	.00	.00	1.00	300.00	00	FD	0.00	1.00	300
18	11 F-SALV	Salv Farm Buildi	.00	.00	1.00	300.00	00	FD	0.00	1.00	300
19	12 F-PS4C12	Pole Shd 4 Sde C	72.00	45.00	3240.00	11.67	1990	F3	85.00	1.00	5,670
20	13 F-SALV	Salv Farm Buildi	.00	.00	1.00	300.00	00	FD	0.00	1.00	300
21	14 F-SALV	Salv Farm Buildi	.00	.00	1.00	300.00	00	FD	0.00	1.00	300
22	15 F-SALV	Salv Farm Buildi	.00	.00	1.00	300.00	00	FD	0.00	1.00	300
23	7 F-PSNE	Pole Shd No Elec	60.00	20.00	1200.00	.92	1966	F3	85.00	1.00	170-