

LOT 1 STONEHENGE

COLUMBIA IL 62236
Site Address: 009101 WILTSHIRE DR

BLDG # 1
 Style/Stories 2.0 2 Story
 Quality/Design C C-Average
 Building Use 0100 Single Fami
 Exterior Wall M Masonry 2.0
 WALL % 050 050%
 Exterior Wall 1 F Frame
 WALL 1% 050 050%
 Crawl Sp. Adj C Crawl
 Slab Adjustment
 Basement RC C-Rec Room
 Combination
 Attic Area
 Heat/AC Adj AC Central Air
 Comb Ht/AC Adj
 Fireplace 03 C-Fireplace
 Extra Fireplace 00 N/A
 Res Fixtures 0019 19 Fixtures
 Garage M Masonry Gar
 Integral Garage IG Integral Ga
 Remodeling Adj 01 No Remodeli
 Actual Year Blt 2015
 Effect Year Blt 2015
 Cond/Desir/Util A
 Township Multpl 05 Res CDU - A
 TOWNSHIP #0
 Funct. Obs. % 000000
 Economic Obs. % 000000
 Observed Cond % 000000
 Obs. Cond. Code
 Combination A
 Comb A Ht/AC
 Unfin Low/Level
 Full Basement F Full Baseme
 # Of Bedrooms 04 Four Bedroo
 Sq.Ft.Grnd Area 1640

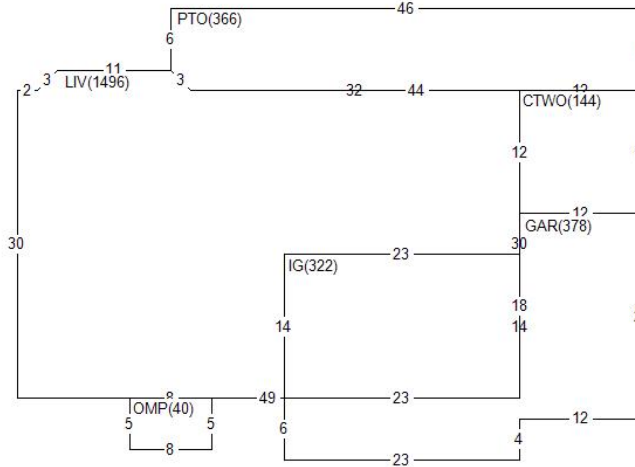

Land Value 86,660
 Misc Value 36,050
 Bldg Value 325,340
 Total Value 448,050
 Value By CAMA

RCN 331,974
 Pct Good 0.9800
 Obsol/Observed 0.0000
 Building Value 325,340

DOCUMENT #	DATE	QS	SALE PRICE
422797	0222	Q	545,000
377622	0615	Q	464,193
373693	1014	28	50,000
PERMIT NO	TYPE	DATE	AMOUNT
13855	10	0615	
13721	00	0615	4
13721	01	1114	
Appraiser JB J. Brown			
Appr Date 03/07/22			
Use Code 0040 Imp Res			
NBHD	409.20	RUL SUB PREM 2.0	
		L100 M100 B155	

AREA	FLAT	EFF% E/AREA	ACT% A/AREA	EA/AA	HEATED
LIV	1496	1.00	1496	1496	1496
CTWO	144	1.00	144	144	144
IG	322	1.00	322	322	322
GAR	378	1.00	378	378	378
PTO	366	1.00	366	366	366
OMP	40	1.00	40	40	40
BSMR	1312	1.00	1312	1312	1312
CRWL	26	1.00	26	26	26

MISC BLDG CODE	DESC	LENGTH	WIDTH	UNITS	ADJ PRICE	EYB DT PCT	ADJUSTMENT	VALUE
1 1 PTO	Concrete Patio	.00	.00	366.00	3.65	2015 A 2.00	1.00	1,310
2 1 OMP	Open Masonry Por	8.00	5.00	40.00	47.50	2015 A 2.00	1.00	1,860
3 1 CONDR	Concrete Drivewa	.00	.00	1580.00	3.65	2015 A 2.00	1.00	5,650
4 1 PTO	Concrete Patio	.00	.00	644.00	3.65	2015 A 2.00	1.00	2,300
5 1 POOLCNC	Concrete Res Poo	32.00	15.00	480.00	50.19	2015 A 2.00	1.00	23,610
6 1 PTO	Concrete Patio	28.00	13.00	364.00	3.65	2017 A 1.00	1.00	1,320
LAND LUSE DESC	ZONING	UNITS	TP	PRICE	ADJUSTMENT	CODE/FACTOR	ADJUSTMENT	VALUE
1 0409 COL RUR SUB #2	MR1	1.00	ST	86660.00	TW	1.00	.00 .00 .00	86,660