

Req By: KRIS_K
HARRY A ROBERTS
166 GLENDALE DR

PART S 1/2 NW

COLUMBIA IL 62236

Site Address: 009613 GILMORE LAKE RD

BLDG # 1
 Style/Stories 1.5 1 1/2 Story
 Quality/Design U U-Unsound
 Building Use 0100 Single Fami
 Exterior Wall M Masonry 1.5
 WALL % 070 070%
 Exterior Wall 1 F Frame
 WALL 1% 030 030%
 Crawl Sp. Adj
 Slab Adjustment
 Basement
 Combination
 Attic Area
 Heat/AC Adj
 Comb Ht/AC Adj
 Fireplace 00 N/A
 Extra Fireplace 00 N/A
 Res Fixtures 0008 08 Fixtures
 Garage
 Integral Garage
 Remodeling Adj 01 No Remodeli
 Actual Year Blt 1929
 Effect Year Blt 1929
 Cond/Desir/Util U Res CDU - U
 Township Multpl 05 TOWNSHIP #0
 Funct. Obs. % 000000
 Economic Obs. % 000000
 Observed Cond % 000000
 Obs. Cond. Code
 Combination A
 Comb A Ht/AC
 Unfin Low/Level
 Full Basement F Full Baseme
 # Of Bedrooms 02 Two Bedroom
 Sq.Ft.Grđ Area 938

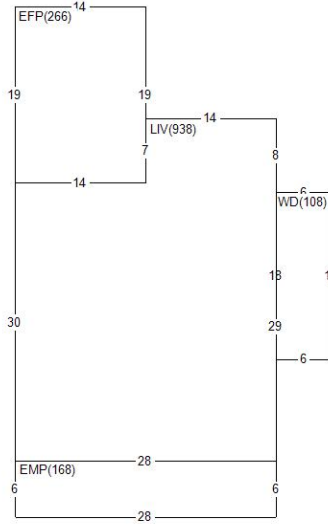

Land Value 0
 Misc Value 27,290
 Bldg Value 2,510
 Total Value 29,800
 Value By CAMA
 RCN 25,084
 Pct Good 0.1000
 Obsol/Observed 0.0000
 Building Value 2,510

DOCUMENT #	DATE	QS	SALE PRICE
	0399	U	140,000
	0996	U	24,000
	0595	U	30,000
PERMIT NO	TYPE	DATE	AMOUNT
NOR	99	1098	
6192	31	0590	

Appraiser JB J. Brown
 Appr Date 10/19/20
 Use Code 0011 Imp. Farm
 NBHD 406.16 1-5 1.5 PR/1940
 L100 M100 B090

AREA	FLAT	EFF%	E/AREA	ACT%	A/AREA	EA/AA	HEATED
WD	108	1.00	108	1.00	108	108	
EMP	168	1.00	168	1.00	168	168	
EFP	266	1.00	266	1.00	266	266	
LIV	938	1.00	938	1.00	938	938	938
PTO	392	1.00	392	1.00	392	392	
GAR	288	1.00	288	1.00	288	288	
SHED	64	1.00	64	1.00	64	64	

MISC BLDG CODE	DESC	LENGTH	WIDTH	UNITS	ADJ PRICE	EYB DT	PCT	ADJUSTMENT	VALUE
1 1 EFP	Enclosed Fr. Por	19.00	14.00	266.00	38.17	1929 P	60.00	1.00	4,060
2 1 EMP	Encl Masonry Por	6.00	28.00	168.00	47.57	1929 P	60.00	1.00	3,200
3 1 GARF	Garage Frame	12.00	24.00	288.00	19.24	1940 A	45.00	1.00	3,050
4 1 SHED	Frame Shed	8.00	8.00	64.00	26.79	1940 A	45.00	1.00	940
5 1 WD	Wood Deck	6.00	18.00	108.00	9.68	1980 P	48.00	.50	540
6 1 PTO	Concrete Patio	14.00	28.00	392.00	3.65	1995 P	33.00	1.00	960

Req By: KRIS_K
HARRY A ROBERTS
166 GLENDALE DR

			COLUMBIA		IL 62236						
			Site Address: 009613		GILMORE LAKE		RD				
MISC	BLDG CODE	DESC	LENGTH	WIDTH	UNITS	ADJ PRICE	EYB DT	PCT	ADJUSTMENT	VALUE	
7	1 F-SALV	Salv Farm Buildi	.00	.00	1.00	300.00	00 FD	0.00	1.00	300	
8	2 F-SALV	Salv Farm Buildi	.00	.00	1.00	300.00	00 FD	0.00	1.00	300	
9	3 F-FRSHED14	Frame Shed 14'	28.00	24.00	672.00	13.10	1932 F3	85.00	.50	1,320	
10	4 F-SALV	Salv Farm Buildi	.00	.00	1.00	300.00	00 FD	0.00	1.00	300	
11	5 F-SALV	Salv Farm Buildi	.00	.00	1.00	300.00	00 FD	0.00	1.00	300	
12	6 F-PS4C14	Pole Shd 4 Sde C	60.00	40.00	2400.00	9.74	1966 F3	85.00	.75	3,510	
13	6 F-PSCFL	Pole Shd Conc Fl	21.00	21.00	441.00	3.65	1966 F3	85.00	1.00	240	
14	7 F-LTP	Lean-to Pole	60.00	20.00	1200.00	4.60	1966 F3	85.00	.75	830	
15	8 F-CONC	Farm Concrete	32.00	16.00	512.00	1.83	1960 F3	85.00	.50	140	
16	9 F-SALV	Salv Farm Buildi	.00	.00	1.00	300.00	00 FD	0.00	1.00	300	
17	10 F-SALV	Salv Farm Buildi	.00	.00	1.00	300.00	00 FD	0.00	1.00	300	
18	11 F-SALV	Salv Farm Buildi	.00	.00	1.00	300.00	00 FD	0.00	1.00	300	
19	12 F-PS4C12	Pole Shd 4 Sde C	72.00	45.00	3240.00	11.67	1990 F3	85.00	1.00	5,670	
20	13 F-SALV	Salv Farm Buildi	.00	.00	1.00	300.00	00 FD	0.00	1.00	300	
21	14 F-SALV	Salv Farm Buildi	.00	.00	1.00	300.00	00 FD	0.00	1.00	300	
22	15 F-SALV	Salv Farm Buildi	.00	.00	1.00	300.00	00 FD	0.00	1.00	300	
23	7 F-PSNE	Pole Shd No Elec	60.00	20.00	1200.00	.92	1966 F3	85.00	1.00	170-	