

PART TAX LOTS 7 & 8

COLUMBIA IL 62236

Site Address: 000000 GILMORE LAKE RD

BLDG # 1
Style/Stories 1.0 One Story
Quality/Design C C-Average
Building Use 0100 Single Fami
Exterior Wall F Frame
WALL % 100 100%
Exterior Wall 1
WALL 1% 000 N/A
Crawl Sp. Adj C Crawl
Slab Adjustment
Basement
Combination
Attic Area
Heat/AC Adj AC Central Air
Comb Ht/AC Adj
Fireplace 03 C-Fireplace
Extra Fireplace 00 N/A
Res Fixtures 0012 12 Fixtures
Garage F Frame Garag
Integral Garage
Remodeling Adj 01 No Remodeli
Actual Year Blt 2007
Effect Year Blt 2007
Cond/Desir/Util A Res CDU - A
Township Multpl 05 TOWNSHIP #0
Funct. Obs. %
Economic Obs. %
Observed Cond %
Obs. Cond. Code
Combination A
Comb A Ht/AC
Unfin Low/Level
Full Basement F Full Baseme
Of Bedrooms 03 Three Bedro
Sq.Ft.Grnd Area 2118

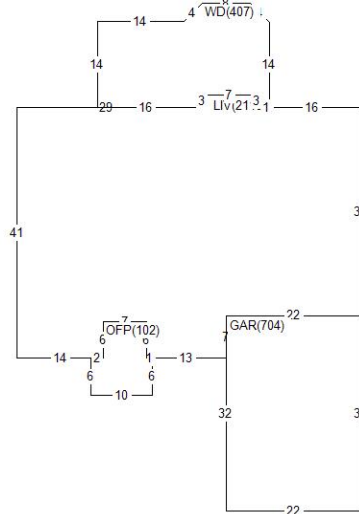

Land Value 32,000
Misc Value 47,680
Bldg Value 154,370
Total Value 234,050
Value By CAMA

RCN 165,987
Pct Good 0.9300
Obsol/Observed 0.0000
Building Value 154,370

DOCUMENT #	DATE QS	SALE PRICE
318581	1007 U	
303425	0106 U	273,305

PERMIT NO	TYPE	DATE	AMOUNT
15752	86	1021	
12181	00	1207	
12181	01	0707	

Appraiser JB J. Brown
Appr Date 10/19/20
Use Code 0011 Imp. Farm
NBHD 406.50 1-5 RES W/O HSE L100 M100 B098

AREA	FLAT	EFF%	E/AREA	ACT%	A/AREA	EA/AA	HEATED
CONDR	900	1.00	900	1.00	900	900	
CRWL	18	1.00	18	1.00	18	18	
LIV	2118	1.00	2118	1.00	2118	2118	2118
GAR	704	1.00	704	1.00	704	704	
WD	407	1.00	407	1.00	407	407	
OPFP	102	1.00	102	1.00	102	102	

MISC BLDG CODE	DESC	LENGTH	WIDTH	UNITS	ADJ PRICE	EYB DT PCT	ADJUSTMENT	VALUE
1	1 OPFP	Open Frame Porch	.00	.00	102.00	26.86 2007 A 7.00	1.00	2,550
2	1 WD	Wood Deck	.00	.00	407.00	19.35 2007 A 7.00	1.00	7,320
3	1 CONDR	Concrete Drivewa	30.00	30.00	900.00	3.65 2007 A 7.00	1.00	3,060
4	1 BRVEN	Brick Veneer	.00	.00	744.00	14.65 2007 A 7.00	1.00	10,140
5	1 F-PS4C12	Pole Shd 4 Sde C	50.00	36.00	1800.00	13.25 2007 F3 67.50	1.00	7,750
6	2 F-PS4C12	Pole Shd 4 Sde C	60.00	36.00	2160.00	12.76 2007 F3 67.50	1.00	8,960

LAND LUSE DESC	ZONING	UNITS TP	PRICE	ADJUSTMENT	CODE/FACTOR	VALUE
1 CE County Road Cat.	MAL	2.50 R	12800.00	TW	1.00 .00 .00 .00	32,000

Req By: KRIS_K
 EDWIN A & NANCY L MCLEAN
 9156 GILMORE LAKE RD

			COLUMBIA		IL 62236							
Site Address: 000000			GILMORE LAKE		RD							
MISC	BLDG CODE	DESC	LENGTH	WIDTH	UNITS	ADJ	PRICE	EYB	DT	PCT	ADJUSTMENT	VALUE
7	2 F-PSCFL	Pole Shd Conc Fl	12.00	60.00	720.00		3.65	2007	F3	67.50	1.00	850
8	3 F-PS4C14	Pole Shd 4 Sde C	18.00	36.00	648.00		19.71	2007	F3	67.50	1.00	4,150
9	4 F-LTP	Lean-to Pole	36.00	11.00	396.00		7.25	2015	F3	31.50	1.00	1,970
10	5 F-PS4C08	Pole Shd 4 Sde C	10.00	10.00	100.00		16.36	2015	F3	31.50	1.00	1,120
11	3 F-PSNE	Pole Shd No Elec	18.00	36.00	648.00		.92	2007	F3	67.50	1.00	190-