

Req By: KRIS_K
DAVID J & TRACEY A HOLMES
9420 GILMORE LAKE RD

PART SE 1/4

COLUMBIA IL 62236
Site Address: 009420 GILMORE LAKE RD

BLDG # 1
 Style/Stories 1.0 One Story
 Quality/Design C C-Average
 Building Use 0100 Single Fami
 Exterior Wall F Frame
 WALL % 100 100%
 Exterior Wall 1
 WALL 1% 000 N/A
 Crawl Sp. Adj
 Slab Adjustment
 Basement LC C-Living Qt
 Combination
 Attic Area
 Heat/AC Adj AC Central Air
 Comb Ht/AC Adj
 Fireplace 31 DirectVent
 Extra Fireplace 00 N/A
 Res Fixtures 0017 17 Fixtures
 Garage F Frame Garag
 Integral Garage
 Remodeling Adj 01 No Remodeli
 Actual Year Blt 2018
 Effect Year Blt 2018
 Cond/Desir/Util A Res CDU - A
 Township Multpl 05 TOWNSHIP #0
 Funct. Obs. % 000000
 Economic Obs. % 000000
 Observed Cond % 000000
 Obs. Cond. Code
 Combination A
 Comb A Ht/AC
 Unfin Low/Level
 Full Basement
 # Of Bedrooms 03 Three Bedro
 Sq.Ft.Grd Area 3124

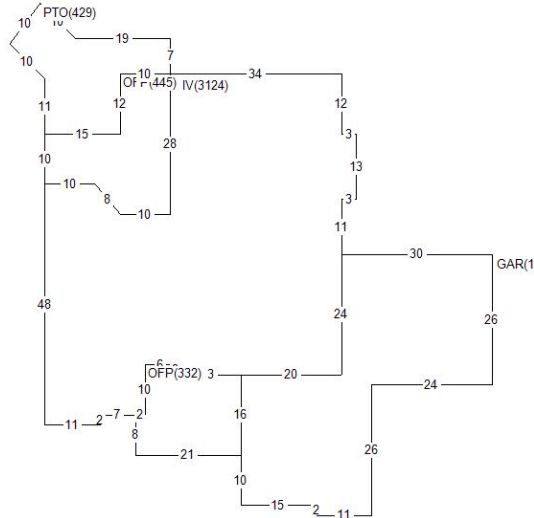

Land Value 32,000
 Misc Value 91,230
 Bldg Value 547,830
 Total Value 671,060
 Value By CAMA

RCN 553,367
 Pct Good 0.9900
 Obsol/Observed 0.0000
 Building Value 547,830

DOCUMENT #	DATE	QS	SALE PRICE
410855	0920	U	975,000

PERMIT NO	TYPE	DATE	AMOUNT
-----------	------	------	--------

Appraiser KK K. Kenned
 Appr Date 01/25/22
 Use Code 0011 Imp. Farm
 NBHD 406.10 1-5 1.0 40/NEW
 L100 M100 B202

AREA	FLAT	EFF% E/AREA	ACT% A/AREA	EA/AA HEATED
LIV	3124	1.00	3124 1.00	3124 3124
GAR	1466	1.00	1466 1.00	1466 1466
OFFP	777	1.00	777 1.00	777 777
PTO	429	1.00	429 1.00	429 429
CONDR	2808	1.00	2808 1.00	2808 2808
BSML	2172	1.00	2172 1.00	2172 2172

MISC BLDG CODE	DESC	LENGTH	WIDTH	UNITS	ADJ PRICE	EYB DT PCT	ADJUSTMENT	VALUE
1 1 PS4C08	Pole Shd 4 Sde C	72.00	42.00	3024.00	10.64	2006 20 72.25	1.00	8,930
3 1 OFFP	Open Frame Porch	.00	.00	2080.00	19.80	2010 A 5.00	1.00	39,130
4 1 OFFP	Open Frame Porch	.00	.00	332.00	22.48	2018 A 1.00	1.00	7,390
5 1 CONDR	Concrete Drivewa	.00	.00	2808.00	3.65	2018 A 1.00	1.00	10,150
6 1 OFFP	Open Frame Porch	.00	.00	445.00	21.47	2018 A 1.00	1.00	9,460
7 1 PTO	Concrete Patio	.00	.00	429.00	3.65	2018 A 1.00	1.00	1,550
LAND LUSE DESC	ZONING	UNITS TP	PRICE	ADJUSTMENT	CODE/FACTOR	ADJUSTMENT	VALUE	
1 CE County Road Cat.	MAL	2.50 R	12800.00	TW 1.00	.00	.00	32,000	

MISC	BLDG CODE	DESC	Site Address:	COLUMBIA	IL 62236	GILMORE LAKE	RD	ADJ	PRICE	EYB	DT	PCT	ADJUSTMENT	VALUE
			LENGTH	WIDTH	UNITS									
8	1 BRVEN	Brick Veneer	.00	.00	644.00				14.65	2018	A	1.00	1.00	9,340
9	1 F-FRSHED08	Frame Shed 8'	22.00	12.00	264.00				25.81	2017	F3	22.50	1.00	5,280