

PART SE 1/4

COLUMBIA IL 62236  
 Site Address: 004921 WILD HORSE DR

BLDG # 1  
 Style/Stories 1.0 One Story  
 Quality/Design C C-Average  
 Building Use 0100 Single Fami  
 Exterior Wall F Frame  
 WALL % 100 100%  
 Exterior Wall 1  
 WALL 1% 000 N/A  
 Crawl Sp. Adj C Crawl  
 Slab Adjustment  
 Basement  
 Combination  
 Attic Area  
 Heat/AC Adj AC Central Air  
 Comb Ht/AC Adj  
 Fireplace 03 C-Fireplace  
 Extra Fireplace 31 DirectVent  
 Res Fixtures 0020 20 Fixtures  
 Garage F Frame Garag  
 Integral Garage  
 Remodeling Adj 01 No Remodeli  
 Actual Year Blt 2022  
 Effect Year Blt 2022  
 Cond/Desir/Util A Res CDU - A  
 Township Multpl 05 TOWNSHIP #0  
 Funct. Obs. % 000000  
 Economic Obs. % 000000  
 Observed Cond % 000000  
 Obs. Cond. Code  
 Combination A  
 Comb A Ht/AC  
 Unfin Low/Level  
 Full Basement  
 # Of Bedrooms 06 Six Bedroom  
 Sq.Ft.Grd Area 4060

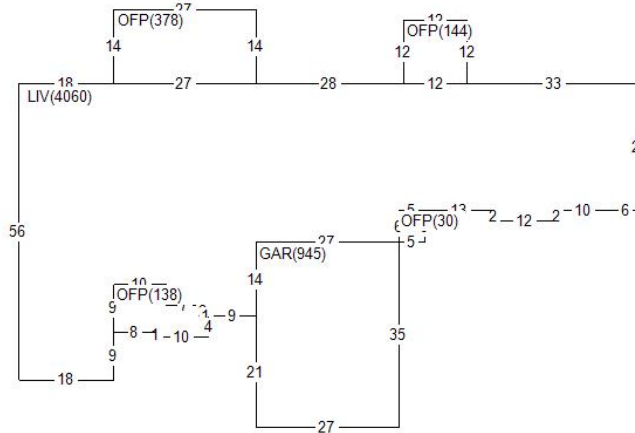

Land Value 66,310  
 Misc Value 25,800  
 Bldg Value 628,650  
 Total Value 720,760  
 Value By CAMA

RCN 628,652  
 Pct Good 1.0000  
 Obsol/Observed 0.0000  
 Building Value 628,650

DOCUMENT # DATE QS SALE PRICE  
 408210 0520 Q 156,000

PERMIT NO TYPE DATE AMOUNT  
 15712 01 0821

Appraiser DG D. Goff  
 Appr Date 03/22/24  
 Use Code 0040 Imp Res  
 NBHD 406.10 1-5 1.0 40/NEW  
 L100 M100 B202

AREA	FLAT	EFF% E/AREA	ACT% A/AREA	EA/AA HEATED
LIV	4060	1.00	4060	4060
OFF	690	1.00	690	690
GAR	945	1.00	945	945
CRWL	1251	1.00	1251	1251

MISC BLDG CODE	DESC	LENGTH	WIDTH	UNITS	ADJ PRICE	EYB DT PCT	ADJUSTMENT	VALUE
1 1 OFFP	Open Frame Porch	14.00	27.00	378.00	21.99	2022 A 0.00	1.00	8,310
2 1 OFFP	Open Frame Porch	12.00	12.00	144.00	24.29	2022 A 0.00	1.00	3,500
3 1 OFFP	Open Frame Porch	.00	.00	138.00	24.58	2022 A 0.00	1.00	3,390
4 1 CONDR	Concrete Drivewa	.00	.00	2904.00	3.65	2022 A 0.00	1.00	10,600

LAND LUSE DESC	ZONING	UNITS TP	PRICE	ADJUSTMENT	CODE/FACTOR	VALUE
1 CE County Road Cat.	MA1	8.02 R	8268.16	TW 1.00	.00 .00	66,310