

PART LOT 10 STONEHENGE

COLUMBIA IL 62236
 Site Address: 009100 WILTSHIRE DR

BLDG # 1
 Style/Stories 2.0 2 Story
 Quality/Design C C-Average
 Building Use 0100 Single Fami
 Exterior Wall F Frame 2.0
 WALL % 055 055%
 Exterior Wall 1 M Masonry
 WALL 1% 045 045%
 Crawl Sp. Adj
 Slab Adjustment
 Basement
 Combination M1 Masonry/1.0
 Attic Area
 Heat/AC Adj AC Central Air
 Comb Ht/AC Adj AC1 Cent AC Cmb
 Fireplace 33 2-DirectVen
 Extra Fireplace 00 N/A
 Res Fixtures 0017 17 Fixtures
 Garage M Masonry Gar
 Integral Garage
 Remodeling Adj 01 No Remodeli
 Actual Year Blt 2007
 Effect Year Blt 2007
 Cond/Desir/Util A Res CDU - A
 Township Multpl 05 TOWNSHIP #0
 Funct. Obs. %
 Economic Obs. %
 Observed Cond %
 Obs. Cond. Code
 Combination A
 Comb A Ht/AC
 Unfin Low/Level
 Full Basement F Full Baseme
 # Of Bedrooms 04 Four Bedroo
 Sq.Ft.Grnd Area 2714

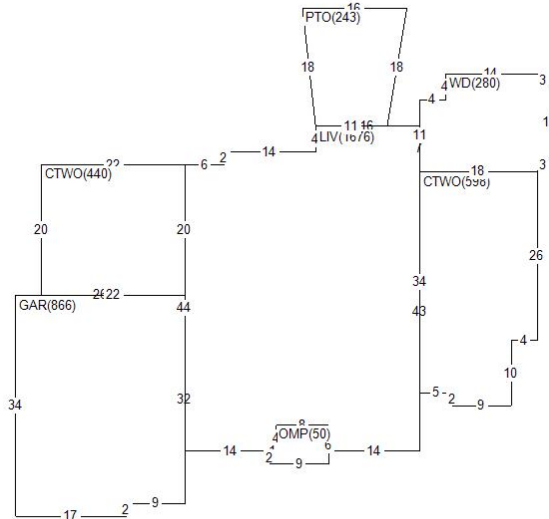

Land Value 86,660
 Misc Value 52,030
 Bldg Value 520,890
 Total Value 659,580
 Value By CAMA

RCN 560,094
 Pct Good 0.9300
 Obsol/Observed 0.0000
 Building Value 520,890

DOCUMENT #	DATE	QS	SALE PRICE
404956	1119	U	
312190	0107	Q	80,000

PERMIT NO	TYPE	DATE	AMOUNT
13856	00	1217	
13856	10	0615	
12126	00	1107	

Appraiser JB J. Brown
 Appr Date 10/19/20
 Use Code 0040 Imp Res
 NBHD 409.20 RUL SUB PREM 2.0
 L100 M100 B186

AREA	FLAT	EFF% E/AREA	ACT% A/AREA	EA/AA HEATED
CONDR	2710	1.00	2710	2710
GAR	866	1.00	866	866
LIV	1676	1.00	1676	1676
CTWO	1038	1.00	1038	1038
OMP	50	1.00	50	50
WD	280	1.00	280	280
PTO	1428	1.00	1428	1428
POOL	561	1.00	561	561
OFFP	144	1.00	144	144

MISC BLDG CODE	DESC	LENGTH	WIDTH	UNITS	ADJ PRICE	EYB DT PCT	ADJUSTMENT	VALUE
1	1 OMP	.00	.00	50.00	43.75	2007 A 7.00	1.00	2,040
2	1 WD	.00	.00	280.00	19.35	2007 A 7.00	1.00	5,040
3	1 PTO	.00	.00	243.00	3.65	2007 A 7.00	1.00	830
4	1 CONDR	.00	.00	2710.00	3.65	2007 A 7.00	1.00	9,200
5	1 BRVEN	.00	.00	22.00	14.65	2007 A 7.00	1.00	300
6	1 POOLCNC	.00	.00	561.00	49.02	2015 A 2.00	1.00	26,950

LAND LUSE DESC	ZONING	UNITS TP	PRICE	ADJUSTMENT CODE/FACTOR	VALUE
1 0409 COL RUR SUB #2	MR1	1.00 ST	86660.00	TW 1.00 .00 .00 .00	86,660

MISC BLDG CODE		DESC	Site Address:	COLUMBIA	WILTSHIRE	IL 62236	DR	ADJUSTMENT		VALUE
			LENGTH	WIDTH	UNITS	ADJ PRICE	EYB DT PCT			
7	1 PTO	Concrete Patio	.00	.00	1025.00	3.65	2015 A 2.00	1.00		3,670
8	1 OFP	Open Frame Porch	12.00	12.00	144.00	24.29	2017 A 2.00	1.00		3,430
9	1 PTO	Concrete Patio	.00	.00	160.00	3.65	2017 A 2.00	1.00		570