

PART LOT 2

VALMEYER IL 62295

Site Address: 001848 ZIEBOLD RD

BLDG # 1
 Style/Stories 1.0 One Story
 Quality/Design C C-Average
 Building Use 0100 Single Fami
 Exterior Wall F Frame
 WALL % 100 100%
 Exterior Wall 1
 WALL 1% 000 N/A
 Crawl Sp. Adj C Crawl
 Slab Adjustment
 Basement
 Combination F2 Frame/2.0
 Attic Area
 Heat/AC Adj AC Central Air
 Comb Ht/AC Adj AC2 Cent AC Cmb
 Fireplace 00 N/A
 Extra Fireplace 00 N/A
 Res Fixtures 0011 11 Fixtures
 Garage
 Integral Garage
 Remodeling Adj 04 1/2 - 3/4 U
 Actual Year Blt 1883
 Effect Year Blt 1883
 Cond/Desir/Util A Res CDU - A
 Township Multpl 06 TOWNSHIP #0
 Funct. Obs. % 000000
 Economic Obs. % 000000
 Observed Cond % 000000
 Obs. Cond. Code
 Combination A
 Comb A Ht/AC
 Unfin Low/Level
 Full Basement
 # Of Bedrooms 03 Three Bedro
 Sq.Ft.Grd Area 1696

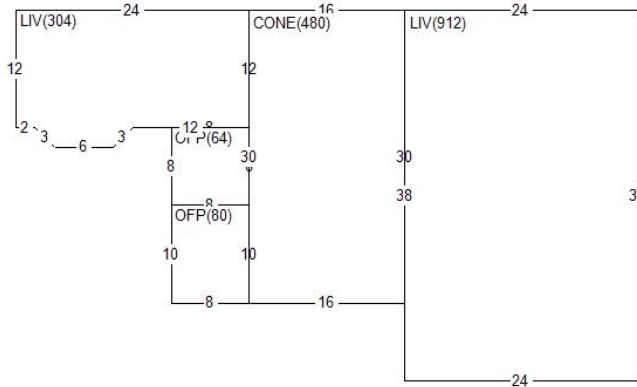

Land Value 15,000
 Misc Value 18,230
 Bldg Value 116,020
 Total Value 149,250
 Value By CAMA

RCN 210,947
 Pct Good 0.5500
 Obsol/Observed 0.0000
 Building Value 116,020

DOCUMENT #	DATE	QS	SALE PRICE
367738	1013	U	70,000
361491	1212	U	
	0794	U	45,000

PERMIT NO	TYPE	DATE	AMOUNT

Appraiser JB J. Brown
 Appr Date 08/09/22
 Use Code 0040 Imp Res
 NBHD 1900.30 FLD PLN PRIOR/40
 L100 M100 B144

AREA	FLAT	EFF% E/AREA	ACT% A/AREA	EA/AA	HEATED
LIV	1216	1.00	1216	1.00	1216
CONE	480	1.00	480	1.00	480
OPF	144	1.00	144	1.00	144
CRWL	976	1.00	976	1.00	976

MISC BLDG CODE	DESC	LENGTH	WIDTH	UNITS	ADJ PRICE	EYB DT PCT	ADJUSTMENT	VALUE
1 1 OFP	Open Frame Porch	8.00	10.00	80.00	14.69	1930 P 60.00	.50	470
2 1 OFP	Open Frame Porch	8.00	8.00	64.00	15.94	1970 P 57.00	.50	440
3 1 SHED	Frame Shed	40.00	28.00	1120.00	21.37	1948 20 85.00	1.00	3,590
4 2 SHED16	Frame Shed 16'	40.00	28.00	1120.00	23.93	1928 20 85.00	1.00	4,020
5 3 SHED	Frame Shed	46.00	20.00	920.00	22.61	1948 20 85.00	1.00	3,120
6 4 SALV	Salvage Structur	.00	.00	1.00	300.00	00 OD 0.00	1.00	300

LAND LUSE DESC	ZONING	UNITS TP	PRICE	ADJUSTMENT	CODE/FACTOR	VALUE
1 CK County Road Cat.	MAL	5.00 R	3000.00	.00	.00 TW 1.00	15,000

MISC	BLDG CODE	DESC	Site Address:	VALMEYER	ZIEBOLD	IL 62295	RD	ADJ PRICE	EYB DT	PCT	ADJUSTMENT	VALUE
			LENGTH	WIDTH	UNITS							
7	5 CONDR	Concrete Drivewa	46.00	14.00	644.00			1.83	2015 P	17.00	.50	980
8	6 SALV	Salvage Structur	.00	.00	1.00			300.00	00 OD	0.00	1.00	300
9	7 SHED	Frame Shed	16.00	12.00	192.00			26.36	2019 A	1.00	1.00	5,010