

PART LOTS 6 & 9

WATERLOO IL 62298

Site Address: 008212 BLUFF RD

BLDG # 1
 Style/Stories 2.0 2 Story
 Quality/Design C C-Average
 Building Use 0100 Single Fami
 Exterior Wall F Frame 2.0
 WALL % 100 100%
 Exterior Wall 1
 WALL 1% 000 N/A
 Crawl Sp. Adj C Crawl
 Slab Adjustment
 Basement RC C-Rec Room
 Combination F1 Frame/1.0
 Attic Area
 Heat/AC Adj AC Central Air
 Comb Ht/AC Adj AC1 Cent AC Cmb
 Fireplace 24 C-2 Fr.Ones
 Extra Fireplace 00 N/A
 Res Fixtures 0012 12 Fixtures
 Garage F Frame Garag
 Integral Garage
 Remodeling Adj 05 Complete Re
 Actual Year Blt 1976
 Effect Year Blt 1976
 Cond/Desir/Util A Res CDU - A
 Township Multpl 06 TOWNSHIP #0
 Funct. Obs. % 000000
 Economic Obs. % 000020
 Observed Cond % 000000
 Obs. Cond. Code
 Combination A
 Comb A Ht/AC
 Unfin Low/Level
 Full Basement
 # Of Bedrooms 04 Four Bedroo
 Sq.Ft.Grd Area 2171

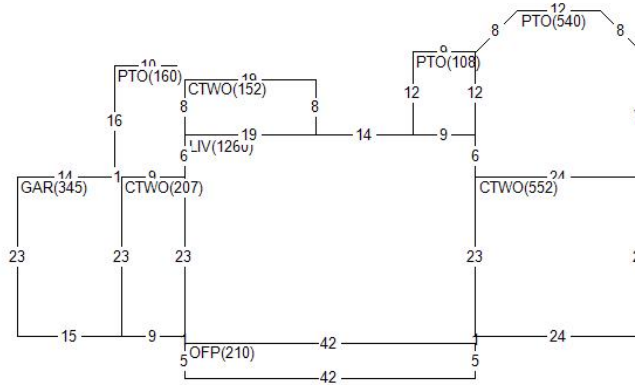

Land Value 58,200
 Misc Value 20,850
 Bldg Value 156,580
 Total Value 235,630
 Value By CAMA

RCN 355,860
 Pct Good 0.6400
 Obsol/Observed 0.2000
 Building Value 156,580

DOCUMENT #	DATE	QS	SALE PRICE
	0499	04	
	0694	U	

PERMIT NO	TYPE	DATE	AMOUNT
7545	31	1293	
8683	31	0996	
7544	01	1293	

Appraiser JB J. Brown
 Appr Date 08/19/22
 Use Code 0011 Imp. Farm
 NBHD 1900.10 FLD PLN 60-NEW
 L100 M100 B154

AREA	FLAT	EFF% E/AREA	ACT% A/AREA	EA/AA	HEATED
CONDR	350	1.00	350	1.00	350
BSMR	875	1.00	875	1.00	875
CRWL	359	1.00	359	1.00	359
LIV	1260	1.00	1260	1.00	1260
PTO	808	1.00	808	1.00	808
CTWO	911	1.00	911	1.00	911
OFFP	210	1.00	210	1.00	210
GAR	345	1.00	345	1.00	345
ASP	4960	1.00	4960	1.00	4960

MISC BLDG CODE	DESC	LENGTH	WIDTH	UNITS	ADJ PRICE	EYB DT PCT	ADJUSTMENT	VALUE
1	1 OFFP	5.00	42.00	210.00	22.96	1999 A 13.00	1.00	4,200
2	1 BRVEN	90.00	8.00	720.00	14.65	1976 A 36.00	1.00	6,750
3	1 PTO	.00	.00	540.00	3.65	1999 A 13.00	1.00	1,720
4	1 PTO	12.00	9.00	108.00	3.65	1999 A 13.00	1.00	340
5	1 PTO	16.00	10.00	160.00	3.65	1999 A 13.00	1.00	510
6	1 CONDR	25.00	14.00	350.00	3.65	1999 A 13.00	1.00	1,110
LAND LUSE DESC	ZONING	UNITS TP	PRICE	ADJUSTMENT	CODE/FACTOR	ADJUSTMENT	VALUE	
1 CJ	County Road Cat.	2.50 R	23280.16	.00	.00	.00 TW 1.00	58,200	

MISC BLDG CODE	DESC	Site Address:	WATERLOO	BLUFF	IL 62298	RD	ADJ PRICE	EYB DT	PCT	ADJUSTMENT	VALUE
7 1 ASP	Asphalt Driveway	008212	LENGTH	WIDTH	UNITS		1.43	2011 F	12.00	.50	6,220
			.00	.00	4960.00						