

LOT 361 NEW VALMEYER PHASE 6

VALMEYER IL 62295

Site Address: 000231 W WOODLAND RIDGE

BLDG # 1  
 Style/Stories 2.0 2 Story  
 Quality/Design C C-Average  
 Building Use 0100 Single Fami  
 Exterior Wall F Frame 2.0  
 WALL % 100 100%  
 Exterior Wall 1  
 WALL 1% 000 N/A  
 Crawl Sp. Adj C Crawl  
 Slab Adjustment  
 Basement  
 Combination F1 Frame/1.0  
 Attic Area  
 Heat/AC Adj AC Central Air  
 Comb Ht/AC Adj AC1 Cent AC Cmb  
 Fireplace 31 DirectVent  
 Extra Fireplace 00 N/A  
 Res Fixtures 0011 11 Fixtures  
 Garage F Frame Garag  
 Integral Garage IG Integral Ga  
 Remodeling Adj 01 No Remodeli  
 Actual Year Blt 2005  
 Effect Year Blt 2005  
 Cond/Desir/Util A  
 Township Multpl 06 TOWNSHIP #0  
 Funct. Obs. %  
 Economic Obs. %  
 Observed Cond %  
 Obs. Cond. Code  
 Combination A  
 Comb A Ht/AC  
 Unfin Low/Level  
 Full Basement F Full Baseme  
 # Of Bedrooms 04 Four Bedroo  
 Sq.Ft.Grđ Area 1683

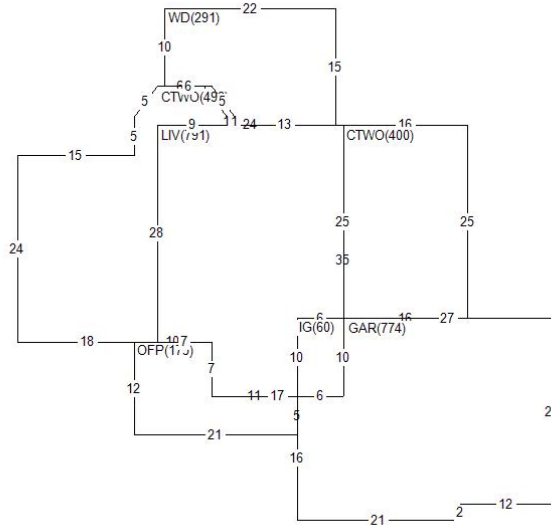

Land Value 26,760  
 Misc Value 19,210  
 Bldg Value 163,050  
 Total Value 209,020  
 Value By CAMA

RCN 177,230  
 Pct Good 0.9200  
 Obsol/Observed 0.0000  
 Building Value 163,050

DOCUMENT #	DATE	QS	SALE PRICE
299978	0805	Q	230,165
295645	0305	Q	44,000
289006	0704	Q	33,653
PERMIT NO	TYPE	DATE	AMOUNT
R1-05-13	01	0405	

Appraiser KS K. Sondag  
 Aprr Date 07/05/22  
 Use Code 0040 Imp Res  
 NBHD 62000.20 VLMYR 2.0 STORY  
 L100 M100 B094

AREA	FLAT	EFF% E/AREA	ACT% A/AREA	EA/AA HEATED
PTO	140	1.00	140	140
CONDR	1047	1.00	1047	1047
CRWL	45	1.00	45	45
OFFP	175	1.00	175	175
LIV	791	1.00	791	791
CTWO	892	1.00	892	892
IG	60	1.00	60	60
GAR	774	1.00	774	774
WD	291	1.00	291	291

MISC BLDG CODE	DESC	LENGTH	WIDTH	UNITS	ADJ PRICE	EYB DT PCT	ADJUSTMENT	VALUE
1	1 OFFP	Open Frame Porch	.00	.00	175.00	23.43 2005 A 8.00	1.00	3,770
2	1 WD	Wood Deck	.00	.00	291.00	19.35 2005 A 8.00	1.00	5,180
3	1 PTO	Concrete Patio	10.00	14.00	140.00	3.65 2005 A 8.00	1.00	470
4	1 CONDR	Concrete Drivewa	.00	.00	1047.00	3.65 2005 A 8.00	1.00	3,520
5	1 BRVEN	Brick Veneer	.00	.00	465.00	14.65 2005 A 8.00	1.00	6,270

LAND LUSE DESC	ZONING	UNITS TP	PRICE	ADJUSTMENT	CODE/FACTOR	VALUE
1 6200 VALMEYER	VR1	1.00 ST	26760.00	TW 1.00	.00 .00 .00	26,760