

Req By: KRIS\_K  
 ADAM L TYBERENDT &  
 STEFANIE JOHNSON-TYBERENDT  
 324 W WOODLAND RIDGE

LOT 383 NEW VALMEYER PHASE 6

VALMEYER IL 62295  
 Site Address: 000324 W WOODLAND RIDGE

BLDG # 1  
 Style/Stories 1.0 One Story  
 Quality/Design C C-Average  
 Building Use 0100 Single Fami  
 Exterior Wall F Frame  
 WALL % 100 100%  
 Exterior Wall 1  
 WALL 1% 000 N/A  
 Crawl Sp. Adj C Crawl  
 Slab Adjustment S Slab  
 Basement RC C-Rec Room  
 Combination  
 Attic Area  
 Heat/AC Adj AC Central Air  
 Comb Ht/AC Adj  
 Fireplace 03 C-Fireplace  
 Extra Fireplace 00 N/A  
 Res Fixtures 0015 15 Fixtures  
 Garage F Frame Garag  
 Integral Garage  
 Remodeling Adj 01 No Remodeli  
 Actual Year Blt 2004  
 Effect Year Blt 2004  
 Cond/Desir/Util A Res CDU - A  
 Township Multpl 06 TOWNSHIP #0  
 Funct. Obs. %  
 Economic Obs. %  
 Observed Cond %  
 Obs. Cond. Code  
 Combination A  
 Comb A Ht/AC  
 Unfin Low/Level  
 Full Basement F Full Baseme  
 # Of Bedrooms 04 Four Bedroo  
 Sq.Ft.Grnd Area 2246

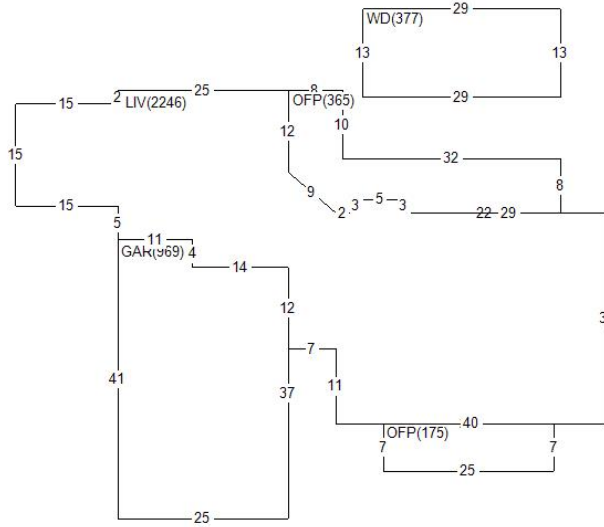

Land Value 26,760  
 Misc Value 27,280  
 Bldg Value 199,990  
 Total Value 254,030  
 Value By CAMA

RCN 219,774  
 Pct Good 0.9100  
 Obsol/Observed 0.0000  
 Building Value 199,990

DOCUMENT #	DATE	QS	SALE PRICE
413043	1220	U	270,000
378556	0715	U	
358965	0912	Q	225,000
PERMIT NO	TYPE	DATE	AMOUNT
R1-13-01	09	0113	
R1-04-24	01	0504	

Appraiser KS K. Sondag  
 Appr Date 07/05/22  
 Use Code 0040 Imp Res  
 NBHD 62000.10 VLMYR 1.0 STORY  
 L100 M100 B118

AREA	FLAT	EFF% E/AREA	ACT% A/AREA	EA/AA	HEATED
CONDR	1612	1.00	1612	1.00	1612
CRWL	14	1.00	14	1.00	14
BSMR	396	1.00	396	1.00	396
OFFP	540	1.00	540	1.00	540
GAR	969	1.00	969	1.00	969
LIV	2246	1.00	2246	1.00	2246
SLAB	225	1.00	225	1.00	225
WD	377	1.00	377	1.00	377

MISC BLDG CODE	DESC	LENGTH	WIDTH	UNITS	ADJ PRICE	EYB DT PCT	ADJUSTMENT	VALUE
1 1 OFFP	Open Frame Porch	7.00	25.00	175.00	23.43	2004 A 9.00	1.00	3,730
2 1 OFFP	Open Frame Porch	.00	.00	365.00	22.13	2004 A 9.00	1.00	7,350
3 1 CONDR	Concrete Drivewa	.00	.00	1612.00	3.65	2004 A 9.00	1.00	5,350
4 1 DORM	Dormer	.00	.00	2.00	1850.00	2004 OD 0.00	1.00	3,700
5 1 WD	Wood Deck	29.00	13.00	377.00	19.35	2015 A 2.00	1.00	7,150

LAND LUSE DESC	ZONING	UNITS TP	PRICE	ADJUSTMENT	CODE/FACTOR	VALUE
1 6200 VALMEYER	VR1	1.00 ST	26760.00	TW 1.00	.00 .00 .00	26,760