

LOT 382 NEW VALMEYER PHASE 6

VALMEYER IL 62295
Site Address: 000332 W WOODLAND RIDGE

BLDG # 1
 Style/Stories 2.0 2 Story
 Quality/Design C C-Average
 Building Use 0100 Single Fami
 Exterior Wall F Frame 2.0
 WALL % 100 100%
 Exterior Wall 1
 WALL 1% 000 N/A
 Crawl Sp. Adj
 Slab Adjustment
 Basement
 Combination F1 Frame/1.0
 Attic Area
 Heat/AC Adj AC Central Air
 Comb Ht/AC Adj AC1 Cent AC Cmb
 Fireplace 31 DirectVent
 Extra Fireplace 00 N/A
 Res Fixtures 0013 13 Fixtures
 Garage F Frame Garag
 Integral Garage
 Remodeling Adj 01 No Remodeli
 Actual Year Blt 2006
 Effect Year Blt 2006
 Cond/Desir/Util A Res CDU - A
 Township Multpl 06 TOWNSHIP #0
 Funct. Obs. %
 Economic Obs. %
 Observed Cond %
 Obs. Cond. Code
 Combination A
 Comb A Ht/AC
 Unfin Low/Level
 Full Basement F Full Baseme
 # Of Bedrooms 04 Four Bedroo
 Sq.Ft.Grđ Area 1033

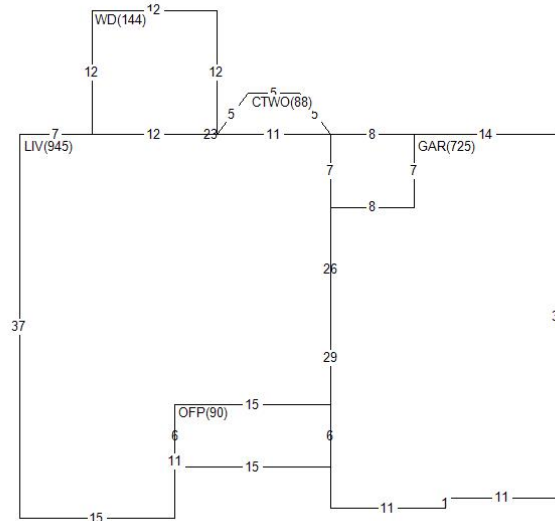

Land Value 26,760
 Misc Value 9,860
 Bldg Value 134,620
 Total Value 171,240
 Value By CAMA

RCN 144,757
 Pct Good 0.9300
 Obsol/Observed 0.0000
 Building Value 134,620

DOCUMENT #	DATE	QS	SALE PRICE
389679	0517	Q	190,000
354871	0312	Q	163,000
295466	0305	Q	31,100

PERMIT NO	TYPE	DATE	AMOUNT
R1-06-28	01	0606	

Appraiser KS K. Sondag
 Appr Date 07/05/22
 Use Code 0040 Imp Res
 NBHD 62000.20 VLMYR 2.0 STORY
 L100 M100 B094

AREA	FLAT	EFF%	E/AREA	ACT%	A/AREA	EA/AA	HEATED
PTO	144	1.00	144	1.00	144	144	
CONDR	1302	1.00	1302	1.00	1302	1302	
OFFP	90	1.00	90	1.00	90	90	
LIV	945	1.00	945	1.00	945	945	945
GAR	725	1.00	725	1.00	725	725	
CTWO	88	1.00	88	1.00	88	88	
WD	144	1.00	144	1.00	144	144	

MISC BLDG CODE	DESC	LENGTH	WIDTH	UNITS	ADJ PRICE	EYB DT PCT	ADJUSTMENT	VALUE
1	1 OFFP	6.00	15.00	90.00	28.19	2006 A 7.00	1.00	2,360
2	1 WD	12.00	12.00	144.00	19.35	2006 A 7.00	1.00	2,590
3	1 PTO	12.00	12.00	144.00	3.65	2006 A 7.00	1.00	490
4	1 CONDR	.00	.00	1302.00	3.65	2006 A 7.00	1.00	4,420

LAND LUSE DESC	ZONING	UNITS TP	PRICE	ADJUSTMENT	CODE/FACTOR	VALUE
1 6200 VALMEYER	VR1	1.00 ST	26760.00	TW 1.00	.00 .00	26,760