

LOT 392 NEW VALMEYER PHASE 6

VALMEYER IL 62295
Site Address: 000300 W WOODLAND RIDGE

BLDG # 1
 Style/Stories 1.0 One Story
 Quality/Design C C-Average
 Building Use 0100 Single Fami
 Exterior Wall F Frame
 WALL % 100 100%
 Exterior Wall 1
 WALL 1% 000 N/A
 Crawl Sp. Adj
 Slab Adjustment
 Basement
 Combination
 Attic Area
 Heat/AC Adj AC Central Air
 Comb Ht/AC Adj
 Fireplace
 Extra Fireplace 00 N/A
 Res Fixtures 0008 08 Fixtures
 Garage F Frame Garag
 Integral Garage
 Remodeling Adj 01 No Remodeli
 Actual Year Blt 2019
 Effect Year Blt 2019
 Cond/Desir/Util A Res CDU - A
 Township Multpl 06 TOWNSHIP #0
 Funct. Obs. % 000000
 Economic Obs. % 000000
 Observed Cond % 000000
 Obs. Cond. Code
 Combination A
 Comb A Ht/AC
 Unfin Low/Level
 Full Basement F Full Baseme
 # Of Bedrooms 03 Three Bedro
 Sq.Ft.Grd Area 1883

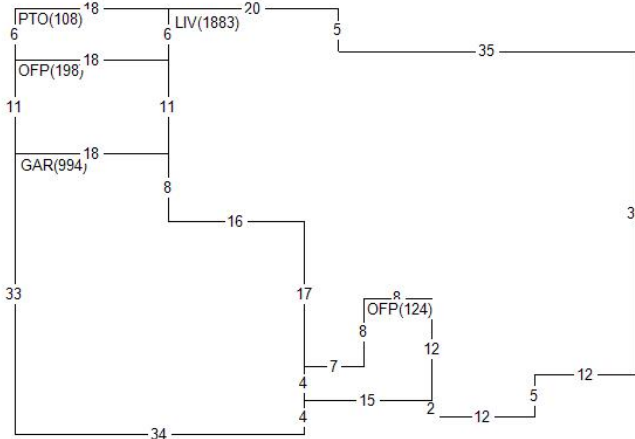

Land Value 26,760
 Misc Value 26,530
 Bldg Value 179,180
 Total Value 232,470
 Value By CAMA

RCN 180,988
 Pct Good 0.9900
 Obsol/Observed 0.0000
 Building Value 179,180

DOCUMENT #	DATE	QS	SALE PRICE
402205	0719	U	
400563	0319	U	25,000
316664	0707	Q	55,000
PERMIT NO	TYPE	DATE	AMOUNT
R1-19-05	00	0819	
R1-19-05	01	0319	

Appraiser KS K. Sondag
 Appr Date 07/06/22
 Use Code 0040 Imp Res
 NBHD 62000.10 VLMYR 1.0 STORY
 L100 M100 B118

AREA	FLAT	EFF% E/AREA	ACT% A/AREA	EA/AA HEATED
LIV	1883	1.00	1883 1.00	1883 1883
GAR	994	1.00	994 1.00	994 994
OFFP	322	1.00	322 1.00	322 322
PTO	108	1.00	108 1.00	108 108
CONDR	1365	1.00	1365 1.00	1365 1365
SHED	432	1.00	432 1.00	432 432

MISC BLDG CODE	DESC	LENGTH	WIDTH	UNITS	ADJ PRICE	EYB DT PCT	ADJUSTMENT	VALUE
1 1 OFFP	Open Frame Porch	.00	.00	124.00	25.27	2019 A 1.00	1.00	3,100
2 1 PTO	Concrete Patio	6.00	18.00	108.00	3.65	2019 A 1.00	1.00	390
3 1 OFFP	Open Frame Porch	11.00	18.00	198.00	22.80	2019 A 1.00	1.00	4,470
4 1 CONDR	Concrete Drivewa	39.00	35.00	1365.00	3.65	2019 A 1.00	1.00	4,930
5 1 BRVEN	Brick Veneer	.00	.00	186.00	14.65	2019 A 1.00	1.00	2,700
6 1 SHED	Frame Shed	24.00	18.00	432.00	25.57	2019 A 1.00	1.00	10,940
LAND LUSE DESC	ZONING	UNITS TP	PRICE	ADJUSTMENT	CODE/FACTOR	ADJUSTMENT	VALUE	
1 6200 VALMEYER	VR1	1.00 ST	26760.00	TW 1.00	.00	.00	26,760	