

Req By: KRIS\_K  
ROBERT A LEELING  
MARY J GEOLAT  
110 PEREGRINE LN

LOT 389 NEW VALMEYER PHASE 6

VALMEYER IL 62295

Site Address: 000110 PEREGRINE LN

BLDG # 1  
 Style/Stories 1.0 One Story  
 Quality/Design C C-Average  
 Building Use 0100 Single Fami  
 Exterior Wall F Frame  
 WALL % 100 100%  
 Exterior Wall 1  
 WALL 1% 000 N/A  
 Crawl Sp. Adj  
 Slab Adjustment  
 Basement RC C-Rec Room  
 Combination  
 Attic Area  
 Heat/AC Adj AC Central Air  
 Comb Ht/AC Adj  
 Fireplace 00 N/A  
 Extra Fireplace 00 N/A  
 Res Fixtures 0009 09 Fixtures  
 Garage F Frame Garag  
 Integral Garage  
 Remodeling Adj 01 No Remodeli  
 Actual Year Blt 2005  
 Effect Year Blt 2005  
 Cond/Desir/Util A Res CDU - A  
 Township Multpl 06 TOWNSHIP #0  
 Funct. Obs. %  
 Economic Obs. %  
 Observed Cond %  
 Obs. Cond. Code  
 Combination A  
 Comb A Ht/AC  
 Unfin Low/Level  
 Full Basement F Full Baseme  
 # Of Bedrooms 03 Three Bedro  
 Sq.Ft.Grd Area 1782

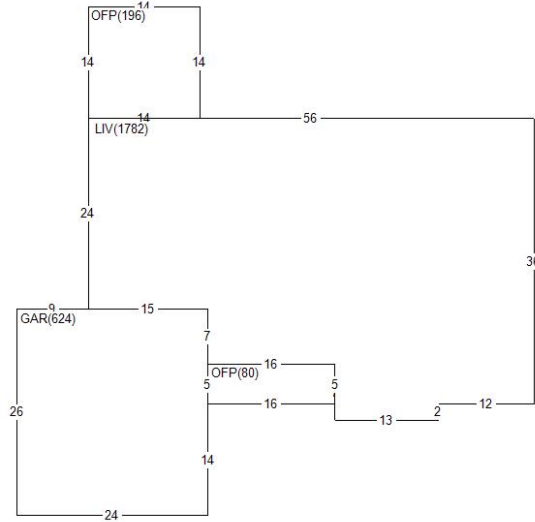

Land Value 26,760  
 Misc Value 16,420  
 Bldg Value 157,190  
 Total Value 200,370  
 Value By CAMA

RCN 170,860  
 Pct Good 0.9200  
 Obsol/Observed 0.0000  
 Building Value 157,190

DOCUMENT #	DATE	QS	SALE PRICE
361806	0113	Q	155,000
285585	0304	Q	31,444

PERMIT NO	TYPE	DATE	AMOUNT
R1-06-01	04	0206	
R1-05-10	01	0405	

Appraiser KS K. Sondag  
 Appr Date 07/06/22  
 Use Code 0040 Imp Res  
 NBHD 62000.10 VLMYR 1.0 STORY  
 L100 M100 B118

AREA	FLAT	EFF%	E/AREA	ACT%	A/AREA	EA/AA	HEATED
CONDR	972	1.00	972	1.00	972	972	
BSMR	896	1.00	896	1.00	896	896	
OFFP	276	1.00	276	1.00	276	276	
LIV	1782	1.00	1782	1.00	1782	1782	1782
GAR	624	1.00	624	1.00	624	624	
PTO	545	1.00	545	1.00	545	545	

MISC BLDG CODE	DESC	LENGTH	WIDTH	UNITS	ADJ PRICE	EYB DT	PCT	ADJUSTMENT	VALUE
1 1 OFFP	Open Frame Porch	5.00	16.00	80.00	29.38	2005 A	8.00	1.00	2,160
2 1 CONDR	Concrete Drivewa	.00	.00	972.00	3.65	2005 F	16.00	1.00	2,980
3 1 OFFP	Open Frame Porch	14.00	14.00	196.00	22.86	2015 A	2.00	1.00	4,390
4 1 PTO	Concrete Patio	.00	.00	545.00	3.65	2013 A	3.00	1.00	1,930
5 1 SHED	Frame Shed	12.00	16.00	192.00	26.36	2015 A	2.00	1.00	4,960

LAND LUSE DESC	ZONING	UNITS TP	PRICE	ADJUSTMENT	CODE/FACTOR	VALUE
1 6200 VALMEYER	VR1	1.00 ST	26760.00	TW 1.00	.00 .00 .00	26,760