

LOT 273 NEW VALMEYER PHASE 5

VALMEYER IL 62295  
Site Address: 000105 FOX POINTE

BLDG # 1  
 Style/Stories 1.0 One Story  
 Quality/Design C C-Average  
 Building Use 0100 Single Fami  
 Exterior Wall F Frame  
 WALL % 100 100%  
 Exterior Wall 1  
 WALL 1% 000 N/A  
 Crawl Sp. Adj  
 Slab Adjustment  
 Basement  
 Combination  
 Attic Area  
 Heat/AC Adj AC Central Air  
 Comb Ht/AC Adj  
 Fireplace C-Fireplace  
 Extra Fireplace 00 N/A  
 Res Fixtures 0009 09 Fixtures  
 Garage F Frame Garag  
 Integral Garage  
 Remodeling Adj 01 No Remodeli  
 Actual Year Blt 2004  
 Effect Year Blt 2004  
 Cond/Desir/Util A Res CDU - A  
 Township Multpl 06 TOWNSHIP #0  
 Funct. Obs. %  
 Economic Obs. %  
 Observed Cond %  
 Obs. Cond. Code  
 Combination A  
 Comb A Ht/AC  
 Unfin Low/Level  
 Full Basement F Full Baseme  
 # Of Bedrooms 03 Three Bedro  
 Sq.Ft.Grnd Area 1761

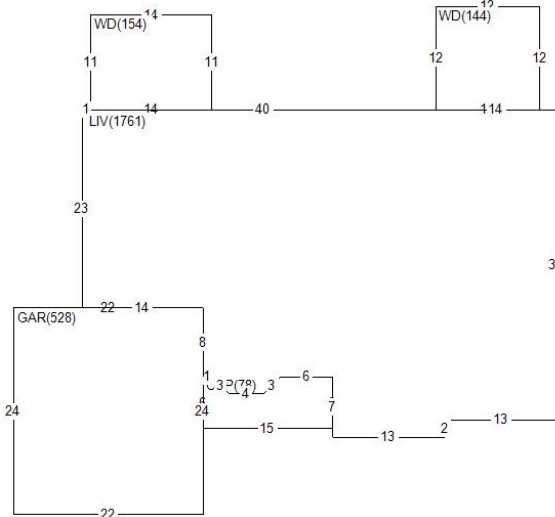

Land Value 26,760  
 Misc Value 18,870  
 Bldg Value 151,370  
 Total Value 197,000  
 Value By CAMA

RCN 166,336  
 Pct Good 0.9100  
 Obsol/Observed 0.0000  
 Building Value 151,370

| DOCUMENT # | DATE | QS   | SALE PRICE |
|------------|------|------|------------|
| 361380     | 1212 | U    |            |
| 287809     | 0504 | Q    | 169,900    |
| 280789     | 1003 | Q    | 21,100     |
| PERMIT NO  | TYPE | DATE | AMOUNT     |
| R1-13-08   | 02   | 1013 |            |
| R1-03-49   | 01   | 1003 |            |

Appraiser KS K. Sondag  
 Appr Date 07/06/22  
 Use Code 0040 Imp Res  
 NBHD 62000.10 VLMYR 1.0 STORY  
 L100 M100 B118

| AREA  | FLAT | EFF% E/AREA | ACT% A/AREA | EA/AA | HEATED |
|-------|------|-------------|-------------|-------|--------|
| OFF   | 78   | 1.00        | 78          | 1.00  | 78     |
| GAR   | 528  | 1.00        | 528         | 1.00  | 528    |
| WD    | 298  | 1.00        | 298         | 1.00  | 298    |
| LIV   | 1761 | 1.00        | 1761        | 1.00  | 1761   |
| CONDR | 1082 | 1.00        | 1082        | 1.00  | 1082   |
| SHED  | 140  | 1.00        | 140         | 1.00  | 140    |

| MISC BLDG CODE  | DESC             | LENGTH   | WIDTH    | UNITS      | ADJ PRICE   | EYB DT PCT   | ADJUSTMENT | VALUE |
|-----------------|------------------|----------|----------|------------|-------------|--------------|------------|-------|
| 1 1 BRVEN       | Brick Veneer     | .00      | .00      | 328.00     | 14.65       | 2004 A 9.00  | 1.00       | 4,370 |
| 2 1 OFP         | Open Frame Porch | .00      | .00      | 78.00      | 29.69       | 2004 A 9.00  | 1.00       | 2,110 |
| 3 1 WD          | Wood Deck        | 11.00    | 14.00    | 154.00     | 19.35       | 2004 F 16.00 | 1.00       | 2,500 |
| 4 1 WD          | Wood Deck        | 12.00    | 12.00    | 144.00     | 15.87       | 2004 F 16.00 | .82        | 1,920 |
| 5 1 CONDR       | Concrete Drivewa | 33.00    | 18.00    | 594.00     | 3.65        | 2004 A 9.00  | 1.00       | 1,970 |
| 6 1 CONDR       | Concrete Drivewa | .00      | .00      | 488.00     | 3.65        | 2005 A 8.00  | 1.00       | 1,640 |
| LAND LUSE DESC  | ZONING           | UNITS TP | PRICE    | ADJUSTMENT | CODE/FACTOR | ADJUSTMENT   | VALUE      |       |
| 1 6200 VALMEYER | VR1              | 1.00 ST  | 26760.00 | TW 1.00    | .00         | .00          | 26,760     |       |

Req By: KRIS\_K  
NEIL B MASSIE  
105 FOX POINTE

| MISC | BLDG CODE | DESC | Site Address: | VALMEYER | FOX POINTE | IL 62295 | LENGTH | WIDTH | UNITS  | ADJ PRICE | EYB DT | PCT  | ADJUSTMENT | VALUE |
|------|-----------|------|---------------|----------|------------|----------|--------|-------|--------|-----------|--------|------|------------|-------|
| 7    | 1         | SHED | 000105        |          |            |          | 14.00  | 10.00 | 140.00 | 26.54     | 2014 A | 2.00 | 1.00       | 3,640 |
| 8    | 1         | PTO  |               |          |            |          | .00    | .00   | 200.00 | 3.65      | 2015 A | 2.00 | 1.00       | 720   |