

LOT 280 NEW VALMEYER PHASE 5

VALMEYER IL 62295

Site Address: 000317 N CEDAR BLUFF DR

BLDG # 1
 Style/Stories 1.0 One Story
 Quality/Design C C-Average
 Building Use 0100 Single Fami
 Exterior Wall F Frame
 WALL % 100 100%
 Exterior Wall 1
 WALL 1% 000 N/A
 Crawl Sp. Adj
 Slab Adjustment
 Basement
 Combination
 Attic Area
 Heat/AC Adj AC Central Air
 Comb Ht/AC Adj
 Fireplace 00 N/A
 Extra Fireplace 00 N/A
 Res Fixtures 0010 10 Fixtures
 Garage F Frame Garag
 Integral Garage
 Remodeling Adj 01 No Remodeli
 Actual Year Blt 2005
 Effect Year Blt 2005
 Cond/Desir/Util A Res CDU - A
 Township Multpl 06 TOWNSHIP #0
 Funct. Obs. %
 Economic Obs. %
 Observed Cond %
 Obs. Cond. Code
 Combination A
 Comb A Ht/AC
 Unfin Low/Level
 Full Basement F Full Baseme
 # Of Bedrooms 03 Three Bedro
 Sq.Ft.Grd Area 1362

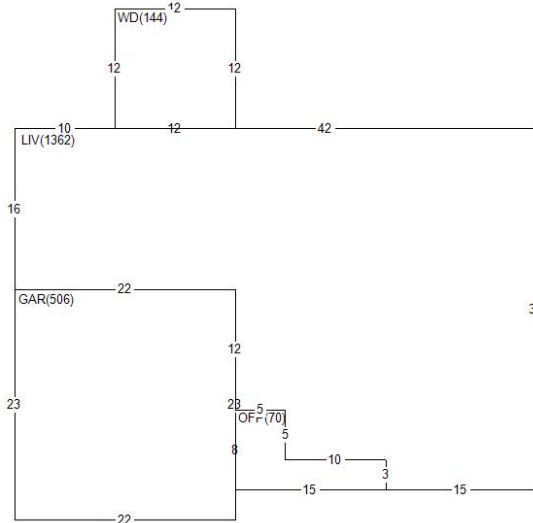

Land Value 26,760
 Misc Value 12,100
 Bldg Value 127,550
 Total Value 166,410
 Value By CAMA

RCN 138,638
 Pct Good 0.9200
 Obsol/Observed 0.0000
 Building Value 127,550

DOCUMENT #	DATE	QS	SALE PRICE
356980	0612	U	
299689	0805	Q	187,479
288393	0604	Q	30,000
PERMIT NO	TYPE	DATE	AMOUNT
R1-05-02	01	0105	

Appraiser KS K. Sondag
 Appr Date 07/06/22
 Use Code 0040 Imp Res
 NBHD 62000.10 VLMYR 1.0 STORY
 L100 M100 B118

AREA	FLAT	EFF% E/AREA	ACT% A/AREA	EA/AA	HEATED
OFF	70	1.00	70	1.00	70
GAR	506	1.00	506	1.00	506
WD	144	1.00	144	1.00	144
LIV	1362	1.00	1362	1.00	1362
PTO	225	1.00	225	1.00	225
CONDR	870	1.00	870	1.00	870

MISC BLDG CODE	DESC	LENGTH	WIDTH	UNITS	ADJ PRICE	EYB DT PCT	ADJUSTMENT	VALUE
1	1 OFP	Open Frame Porch	.00	.00	70.00	30.94 2005 A 8.00	1.00	1,990
2	1 WD	Wood Deck	12.00	12.00	144.00	19.35 2005 A 8.00	1.00	2,560
3	1 CONDR	Concrete Drivewa	29.00	30.00	870.00	3.65 2005 A 8.00	1.00	2,920
4	1 BRVEN	Brick Veneer	.00	.00	288.00	14.65 2005 A 8.00	1.00	3,880
5	1 PTO	Concrete Patio	12.00	12.00	144.00	3.65 2005 A 8.00	1.00	480
6	1 PTO	Concrete Patio	9.00	9.00	81.00	3.65 2005 A 8.00	1.00	270
LAND LUSE DESC	ZONING	UNITS TP	PRICE	ADJUSTMENT	CODE/FACTOR	ADJUSTMENT	VALUE	
1 6200 VALMEYER	VR1	1.00 ST	26760.00	.00	.00	.00 TW 1.00	26,760	