

LOT 330 NEW VALMEYER PHASE 5

VALMEYER IL 62295  
Site Address: 000230 WILLOW RIDGE

BLDG # 1  
 Style/Stories 1.0 One Story  
 Quality/Design C C-Average  
 Building Use 0100 Single Fami  
 Exterior Wall F Frame  
 WALL % 100 100%  
 Exterior Wall 1  
 WALL 1% 000 N/A  
 Crawl Sp. Adj  
 Slab Adjustment  
 Basement  
 Combination  
 Attic Area  
 Heat/AC Adj AC Central Air  
 Comb Ht/AC Adj  
 Fireplace 03 C-Fireplace  
 Extra Fireplace 00 N/A  
 Res Fixtures 0007 07 Fixtures  
 Garage F Frame Garag  
 Integral Garage  
 Remodeling Adj 01 No Remodeli  
 Actual Year Blt 2003  
 Effect Year Blt 2003  
 Cond/Desir/Util A Res CDU - A  
 Township Multpl 06 TOWNSHIP #0  
 Funct. Obs. %  
 Economic Obs. %  
 Observed Cond %  
 Obs. Cond. Code  
 Combination A  
 Comb A Ht/AC  
 Unfin Low/Level  
 Full Basement F Full Baseme  
 # Of Bedrooms 03 Three Bedro  
 Sq.Ft.Grnd Area 2056

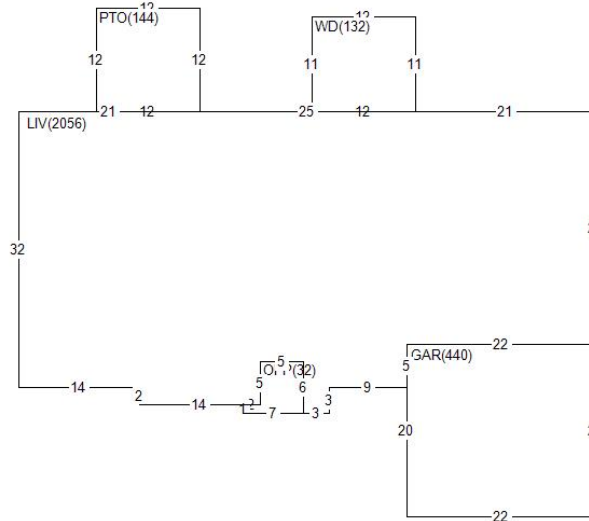

Land Value 26,760  
 Misc Value 36,210  
 Bldg Value 161,270  
 Total Value 224,240  
 Value By CAMA

RCN 179,184  
 Pct Good 0.9000  
 Obsol/Observed 0.0000  
 Building Value 161,270

DOCUMENT #	DATE	QS	SALE PRICE
300449	0905	Q	174,000
278335	0803	Q	25,414

PERMIT NO	TYPE	DATE	AMOUNT
R1-15-04	02	0415	
R1-06-27	04	0806	
R1-03-38	01	0803	

Appraiser KS K. Sondag  
 Appr Date 07/07/22  
 Use Code 0040 Imp Res  
 NBHD 62000.10 VLMYR 1.0 STORY  
 L100 M100 B118

AREA	FLAT	EFF% E/AREA	ACT% A/AREA	EA/AA	HEATED
CONDR	704	1.00	704	1.00	704
PTO	780	1.00	780	1.00	780
OFF	153	1.00	153	1.00	153
WD	533	1.00	533	1.00	533
SHED	80	1.00	80	1.00	80
GAR	440	1.00	440	1.00	440
LIV	2056	1.00	2056	1.00	2056

MISC BLDG CODE	DESC	LENGTH	WIDTH	UNITS	ADJ PRICE	EYB DT PCT	ADJUSTMENT	VALUE
1 1 BRVEN	Brick Veneer	.00	.00	198.00	14.65	2003 A 10.00	1.00	2,610
2 1 PTO	Concrete Patio	12.00	12.00	144.00	3.65	2003 A 10.00	1.00	470
3 1 WD	Wood Deck	11.00	12.00	132.00	19.35	2003 A 10.00	1.00	2,300
4 1 CONDR	Concrete Drivewa	32.00	22.00	704.00	3.65	2003 F 17.00	1.00	2,130
5 1 PTO	Concrete Patio	53.00	12.00	636.00	1.83	2004 P 24.00	.50	880
6 1 OFF	Open Frame Porch	11.00	11.00	121.00	25.49	2006 A 7.00	1.00	2,870
LAND LUSE DESC	ZONING	UNITS TP	PRICE	ADJUSTMENT	CODE/FACTOR	ADJUSTMENT	VALUE	
1 6200 VALMEYER	VR1	1.00 ST	26760.00	TW 1.00	.00	.00	26,760	

MISC BLDG CODE		DESC	Site Address:	VALMEYER	IL 62295	WILLOW RIDGE	UNITS	ADJ PRICE	EYB DT PCT	ADJUSTMENT	VALUE
			LENGTH	WIDTH							
7	1 WD	Wood Deck	.00	.00		401.00	19.35	2006 A	7.00	1.00	7,220
8	1 SHED	Frame Shed	10.00	8.00		80.00	26.74	2007 A	7.00	1.00	1,990
9	1 SHED	Frame Shed	25.00	22.00		550.00	25.02	2015 A	2.00	1.00	13,490
10	1 CPTF	Carport Frame	20.00	12.00		240.00	9.58	2015 A	2.00	1.00	2,250