

LOT 251 NEW VALMEYER PHASE 4

VALMEYER IL 62295  
Site Address: 000109 E WOODLAND RIDGE

BLDG # 1  
 Style/Stories 1.0 One Story  
 Quality/Design C C-Average  
 Building Use 0100 Single Fami  
 Exterior Wall F Frame  
 WALL % 100 100%  
 Exterior Wall 1  
 WALL 1% 000 N/A  
 Crawl Sp. Adj  
 Slab Adjustment  
 Basement  
 Combination  
 Attic Area  
 Heat/AC Adj AC Central Air  
 Comb Ht/AC Adj  
 Fireplace 00 N/A  
 Extra Fireplace 00 N/A  
 Res Fixtures 0005 05 Fixtures  
 Garage F Frame Garag  
 Integral Garage  
 Remodeling Adj 01 No Remodeli  
 Actual Year Blt 1995  
 Effect Year Blt 1995  
 Cond/Desir/Util A Res CDU - A  
 Township Multpl 06 TOWNSHIP #0  
 Funct. Obs. % 000000  
 Economic Obs. % 000000  
 Observed Cond % 000000  
 Obs. Cond. Code  
 Combination A  
 Comb A Ht/AC  
 Unfin Low/Level  
 Full Basement F Full Baseme  
 # Of Bedrooms 02 Two Bedroom  
 Sq.Ft.Grnd Area 1346

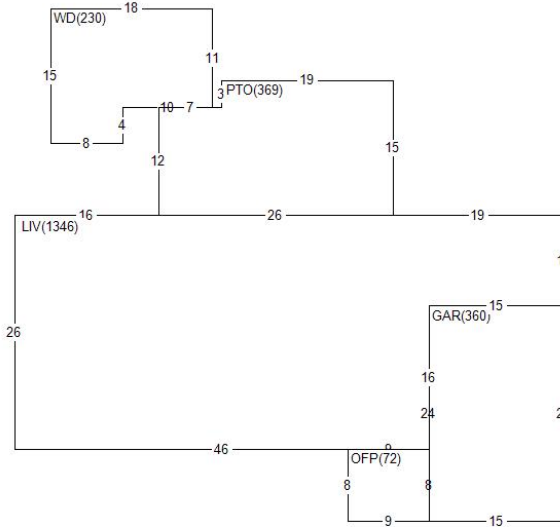

Land Value 26,760  
 Misc Value 17,010  
 Bldg Value 102,850  
 Total Value 146,620  
 Value By CAMA

RCN 123,913  
 Pct Good 0.8300  
 Obsol/Observed 0.0000  
 Building Value 102,850

DOCUMENT #	DATE	QS	SALE PRICE
341219	0710	Q	122,000
314889	0507	04	
	1094	U	5,369
PERMIT NO	TYPE	DATE	AMOUNT
R1-12-02	05	0312	
R1-95-30	01	1195	

Appraiser KS K. Sondag  
 Appr Date 07/08/22  
 Use Code 0040 Imp Res  
 NBHD 62000.10 VLMYR 1.0 STORY  
 L100 M100 B118

AREA	FLAT	EFF% E/AREA	ACT% A/AREA	EA/AA HEATED
OFFP	72	1.00	72 1.00	72 72
GAR	360	1.00	360 1.00	360 360
LIV	1346	1.00	1346 1.00	1346 1346
CONDR	705	1.00	705 1.00	705 705
WD	230	1.00	230 1.00	230 230
PTO	369	1.00	369 1.00	369 369

MISC BLDG CODE	DESC	LENGTH	WIDTH	UNITS	ADJ PRICE	EYB DT PCT	ADJUSTMENT	VALUE
1 1	OFFP	8.00	9.00	72.00	30.63	1995 A 17.00	1.00	1,830
3 1	CONDR	47.00	15.00	705.00	3.65	1995 A 17.00	1.00	2,140
4 1	GARF	22.00	18.00	396.00	19.24	2012 A 3.00	1.00	7,390
5 1	WD	.00	.00	230.00	19.35	2012 A 3.00	1.00	4,320
6 1	PTO	.00	.00	369.00	3.65	2019 A 1.00	1.00	1,330

LAND LUSE DESC	ZONING	UNITS TP	PRICE	ADJUSTMENT	CODE/FACTOR	VALUE
1 6200 VALMEYER	VR1	1.00 ST	26760.00	.00	.00 TW 1.00	26,760