

LOT 350 NEW VALMEYER PHASE 5

VALMEYER IL 62295
Site Address: 000206 STONEHILL RIDGE

BLDG # 1
 Style/Stories 1.0 One Story
 Quality/Design C C-Average
 Building Use 0100 Single Fami
 Exterior Wall F Frame
 WALL % 075 075%
 Exterior Wall 1 M Masonry
 WALL 1% 025 025%
 Crawl Sp. Adj
 Slab Adjustment
 Basement LC C-Living Qt
 Combination
 Attic Area
 Heat/AC Adj AC Central Air
 Comb Ht/AC Adj
 Fireplace 33 2-DirectVen
 Extra Fireplace 00 N/A
 Res Fixtures 0016 16 Fixtures
 Garage M Masonry Gar
 Integral Garage
 Remodeling Adj 01 No Remodeli
 Actual Year Blt 2004
 Effect Year Blt 2004
 Cond/Desir/Util A
 Township Multpl 06 Res CDU - A
 Funct. Obs. % TOWNSHIP #0
 Economic Obs. %
 Observed Cond %
 Obs. Cond. Code
 Combination A
 Comb A Ht/AC
 Unfin Low/Level
 Full Basement F Full Baseme
 # Of Bedrooms 04 Four Bedroo
 Sq.Ft.Grd Area 2144

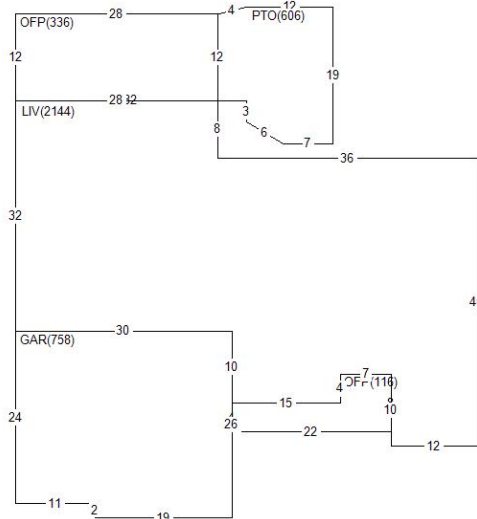

Land Value 26,760
 Misc Value 14,810
 Bldg Value 214,200
 Total Value 255,770
 Value By CAMA

RCN 235,383
 Pct Good 0.9100
 Obsol/Observed 0.0000
 Building Value 214,200

DOCUMENT #	DATE	QS	SALE PRICE
400733	0419	Q	232,000
286833	0404	Q	35,340
283891	0104	Q	29,938
PERMIT NO	TYPE	DATE	AMOUNT
R1-06-09	08	0506	
R1-04-21	01	0504	

Appraiser KS K. Sondag
 Appr Date 07/08/22
 Use Code 0040 Imp Res
 NBHD 62000.10 VLMYR 1.0 STORY
 L100 M100 B118

AREA	FLAT	EFF%	E/AREA	ACT%	A/AREA	EA/AA	HEATED
OFFP	452	1.00	452	1.00	452	452	
GAR	758	1.00	758	1.00	758	758	
PTO	606	1.00	606	1.00	606	606	
LIV	2144	1.00	2144	1.00	2144	2144	2144
BSML	1900	1.00	1900	1.00	1900	1900	
CONDR	1012	1.00	1012	1.00	1012	1012	

MISC BLDG CODE	DESC	LENGTH	WIDTH	UNITS	ADJ PRICE	EYB DT PCT	ADJUSTMENT	VALUE
1 1 OFFP	Open Frame Porch	.00	.00	116.00	25.85	2004 A 9.00	1.00	2,730
2 1 OFFP	Open Frame Porch	12.00	28.00	336.00	22.44	2004 A 9.00	1.00	6,860
3 1 CONDR	Concrete Drivewa	.00	.00	1012.00	3.65	2004 A 9.00	1.00	3,360
5 1 PTO	Concrete Patio	.00	.00	607.00	3.65	2005 F 16.00	1.00	1,860

LAND LUSE DESC	ZONING	UNITS TP	PRICE	ADJUSTMENT	CODE/FACTOR	VALUE
1 6200 VALMEYER	VR1	1.00 ST	26760.00	TW 1.00	.00 .00	26,760