

LOT 7 BLUFF MEADOWS

VALMEYER IL 62295
Site Address: 000440 BLUFF MEADOWS DR

BLDG # 1
 Style/Stories 1.0 One Story
 Quality/Design C C-Average
 Building Use 0100 Single Fami
 Exterior Wall F Frame
 WALL % 100 100%
 Exterior Wall 1
 WALL 1% 000 N/A
 Crawl Sp. Adj
 Slab Adjustment
 Basement
 Combination
 Attic Area
 Heat/AC Adj AC Central Air
 Comb Ht/AC Adj
 Fireplace
 Extra Fireplace 00 DirectVent
 Res Fixtures 0008 08 Fixtures
 Garage F Frame Garag
 Integral Garage
 Remodeling Adj 01 No Remodeli
 Actual Year Blt 2007
 Effect Year Blt 2007
 Cond/Desir/Util A Res CDU - A
 Township Multpl 06 TOWNSHIP #0
 Funct. Obs. %
 Economic Obs. %
 Observed Cond %
 Obs. Cond. Code
 Combination A
 Comb A Ht/AC
 Unfin Low/Level
 Full Basement F Full Baseme
 # Of Bedrooms 03 Three Bedro
 Sq.Ft.Grnd Area 1564

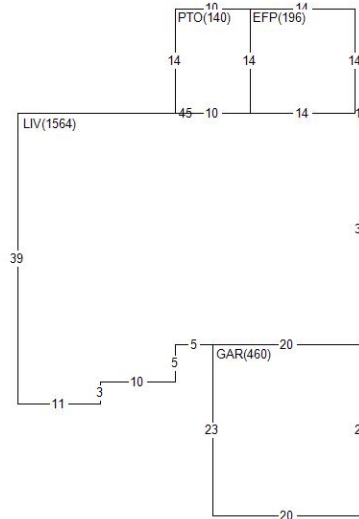

Land Value 26,760
 Misc Value 14,660
 Bldg Value 139,050
 Total Value 180,470
 Value By CAMA

RCN 149,515
 Pct Good 0.9300
 Obsol/Observed 0.0000
 Building Value 139,050

DOCUMENT #	DATE	QS	SALE PRICE
317842	0807	Q	187,000
306996	0606	U	35,625

PERMIT NO	TYPE	DATE	AMOUNT
R2-08-03	07	0608	
R1-06-10	01	0506	

Appraiser KS K. Sondag
 Appr Date 07/20/22
 Use Code 0040 Imp Res
 NBHD 62000.10 VLMYR 1.0 STORY
 L100 M100 B118

AREA	FLAT	EFF% E/AREA	ACT% A/AREA	EA/AA HEATED
CONDR	648	1.00	648	648
GAR	460	1.00	460	460
LIV	1564	1.00	1564	1564
EFP	196	1.00	196	196
PTO	140	1.00	140	140

MISC BLDG CODE	DESC	LENGTH	WIDTH	UNITS	ADJ PRICE	EYB DT PCT	ADJUSTMENT	VALUE
1 1 BRVEN	Brick Veneer	.00	.00	280.00	14.65	2007 A 7.00	1.00	3,820
3 1 CONDR	Concrete Drivewa	36.00	18.00	648.00	3.65	2007 A 7.00	1.00	2,200
4 1 EFP	Enclosed Fr. Por	14.00	14.00	196.00	39.67	2009 A 5.00	1.00	7,390
5 1 PTO	Concrete Patio	14.00	10.00	140.00	3.65	2009 A 5.00	1.00	490
6 1 PTO	Concrete Patio	18.00	12.00	216.00	3.65	2011 A 4.00	1.00	760

LAND LUSE DESC	ZONING	UNITS TP	PRICE	ADJUSTMENT	CODE/FACTOR	VALUE
1 6200 VALMEYER	VR1	1.00 ST	26760.00	TW 1.00	.00 .00 .00	26,760