

Req By: KRIS\_K  
APRIL THOMASON &  
RYAN NABERS  
415 BLUFF MEADOWS DR

LOT 26 & PART OUTLOT 2  
BLUFF MEADOWS

VALMEYER IL 62295  
Site Address: 000415 BLUFF MEADOWS DR

BLDG # 1  
 Style/Stories 1.0 One Story  
 Quality/Design C C-Average  
 Building Use 0100 Single Fami  
 Exterior Wall F Frame  
 WALL % 075 075%  
 Exterior Wall 1 M Masonry  
 WALL 1% 025 025%  
 Crawl Sp. Adj  
 Slab Adjustment  
 Basement  
 Combination  
 Attic Area  
 Heat/AC Adj AC Central Air  
 Comb Ht/AC Adj  
 Fireplace 00 N/A  
 Extra Fireplace 00 N/A  
 Res Fixtures 0009 09 Fixtures  
 Garage M Masonry Gar  
 Integral Garage  
 Remodeling Adj 01 No Remodeli  
 Actual Year Blt 2006  
 Effect Year Blt 2006  
 Cond/Desir/Util A  
 Township Multpl 06 Res CDU - A  
 Funct. Obs. % TOWNSHIP #0  
 Economic Obs. %  
 Observed Cond %  
 Obs. Cond. Code  
 Combination A  
 Comb A Ht/AC  
 Unfin Low/Level  
 Full Basement F Full Baseme  
 # Of Bedrooms 03 Three Bedro  
 Sq.Ft.Grd Area 1964

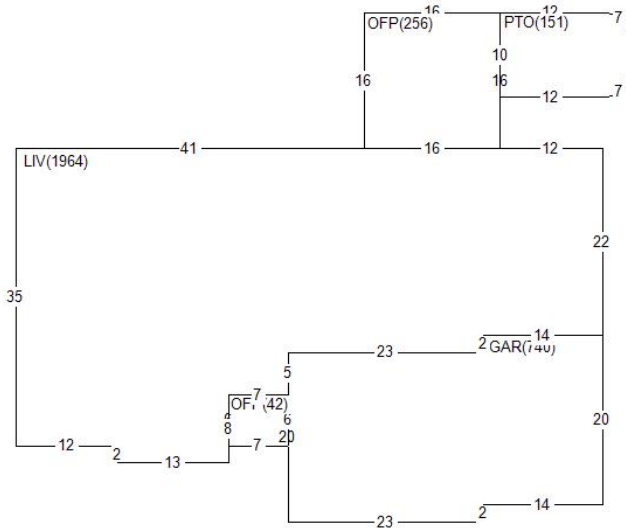

Land Value 26,760  
 Misc Value 12,440  
 Bldg Value 171,840  
 Total Value 211,040  
 Value By CAMA

RCN 184,774  
 Pct Good 0.9300  
 Obsol/Observed 0.0000  
 Building Value 171,840

DOCUMENT #	DATE	QS	SALE PRICE
425417	0722	Q	335,000
405789	0120	U	
401492	0519	U	

PERMIT NO	TYPE	DATE	AMOUNT
R2-10-01	00	0910	
R1-06-26	01	0806	

Appraiser AS A. Schwar  
 Appr Date 08/12/22  
 Use Code 0040 Imp Res  
 NBHD 62000.10 VLMYR 1.0 STORY  
 L100 M100 B118

AREA	FLAT	EFF%	E/AREA	ACT%	A/AREA	EA/AA	HEATED
CONDR	1397	1.00	1397	1.00	1397	1397	
GAR	740	1.00	740	1.00	740	740	
OFFP	298	1.00	298	1.00	298	298	
LIV	1964	1.00	1964	1.00	1964	1964	1964
PTO	151	1.00	151	1.00	151	151	

MISC BLDG CODE	DESC	LENGTH	WIDTH	UNITS	ADJ PRICE	EYB DT PCT	ADJUSTMENT	VALUE
2 1 OFFP	Open Frame Porch	16.00	16.00	256.00	23.68	2006 A 7.00	1.00	5,640
3 1 OFFP	Open Frame Porch	6.00	7.00	42.00	39.25	2006 A 7.00	1.00	1,530
4 1 CONDR	Concrete Drivewa	.00	.00	1397.00	3.65	2006 A 7.00	1.00	4,740
5 1 PTO	Concrete Patio	.00	.00	151.00	3.65	2011 A 4.00	1.00	530

LAND LUSE DESC	ZONING	UNITS TP	PRICE	ADJUSTMENT	CODE/FACTOR	VALUE
1 6200 VALMEYER	VR1	1.00 ST	26760.00	TW 1.00	.00 .00	26,760