

TAX LOT 3D

WATERLOO IL 62298

Site Address: 009506 B RD

BLDG # 1  
 Style/Stories 1.0 One Story  
 Quality/Design C C-Average  
 Building Use 0100 Single Fami  
 Exterior Wall M Masonry 1.0  
 WALL % 100 100%  
 Exterior Wall 1  
 WALL 1% 000 N/A  
 Crawl Sp. Adj  
 Slab Adjustment  
 Basement  
 Combination  
 Attic Area  
 Heat/AC Adj AC Central Air  
 Comb Ht/AC Adj  
 Fireplace 03 C-Fireplace  
 Extra Fireplace 00 N/A  
 Res Fixtures 0005 05 Fixtures  
 Garage M Masonry Gar  
 Integral Garage  
 Remodeling Adj 05 Complete Re  
 Actual Year Blt 1960  
 Effect Year Blt 1960  
 Cond/Desir/Util A Res CDU - A  
 Township Multpl 06 TOWNSHIP #0  
 Funct. Obs. % 000000  
 Economic Obs. % 000000  
 Observed Cond % 000000  
 Obs. Cond. Code  
 Combination A  
 Comb A Ht/AC  
 Unfin Low/Level  
 Full Basement F Full Baseme  
 # Of Bedrooms 03 Three Bedro  
 Sq.Ft.Grđ Area 1201

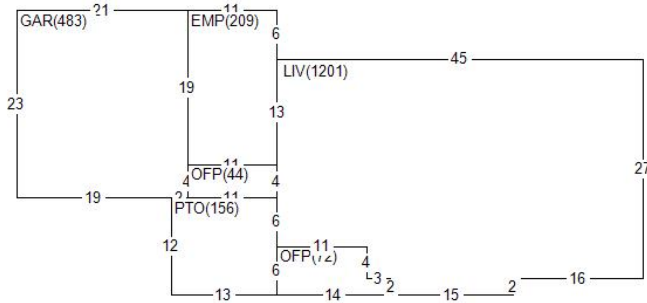

Land Value 2,550  
 Misc Value 14,380  
 Bldg Value 106,550  
 Total Value 123,480  
 Value By CAMA

RCN 193,734  
 Pct Good 0.5500  
 Obsol/Observed 0.0000  
 Building Value 106,550

DOCUMENT #	DATE	QS	SALE PRICE
432869	0424	Q	130,000
289866	0804	07	40,000

PERMIT NO	TYPE	DATE	AMOUNT

Appraiser JB J. Brown  
 Appr Date 05/13/24  
 Use Code 0040 Imp Res  
 NBHD 1900.10 FLD PLN 60-NEW  
 L100 M100 B170

AREA	FLAT	EFF%	E/AREA	ACT%	A/AREA	EA/AA	HEATED
GAR	483	1.00	483	1.00	483	483	
EMP	209	1.00	209	1.00	209	209	
OFP	116	1.00	116	1.00	116	116	
PTO	156	1.00	156	1.00	156	156	
LIV	1201	1.00	1201	1.00	1201	1201	1201
CONDR	1088	1.00	1088	1.00	1088	1088	

MISC BLDG CODE	DESC	LENGTH	WIDTH	UNITS	ADJ PRICE	EYB DT PCT	ADJUSTMENT	VALUE
1	1 OFP	Open Frame Porch	.00	.00	72.00	30.63 1960 A 45.00	1.00	1,210
2	1 EMP	Encl Masonry Por	19.00	11.00	209.00	46.13 1960 A 45.00	1.00	5,300
3	1 CONDR	Concrete Drivewa	68.00	16.00	1088.00	3.65 1960 P 60.00	1.00	1,590
4	1 PTO	Concrete Patio	12.00	13.00	156.00	3.65 1995 A 18.00	1.00	470
5	1 SHED	Frame Shed	16.00	30.00	480.00	25.41 1960 P 60.00	1.00	4,880
6	1 OFP	Open Frame Porch	4.00	11.00	44.00	38.50 1960 A 45.00	1.00	930
LAND LUSE DESC	ZONING	UNITS TP	PRICE	ADJUSTMENT	CODE/FACTOR	ADJUSTMENT	VALUE	
1 CK	County Road Cat.	MAL	.85 R	3000.00	.00	.00 .00 TW 1.00	2,550	