

PART LOT 9

COLUMBIA IL 62236
Site Address: 009746 B RD

BLDG # 1
 Style/Stories 2.0 2 Story
 Quality/Design C C-Average
 Building Use 0100 Single Fami
 Exterior Wall F Frame 2.0
 WALL % 100 100%
 Exterior Wall 1
 WALL 1% 000 N/A
 Crawl Sp. Adj C Crawl
 Slab Adjustment
 Basement
 Combination F1 Frame/1.0
 Attic Area
 Heat/AC Adj AC Central Air
 Comb Ht/AC Adj AC1 Cent AC Cmb
 Fireplace 00 N/A
 Extra Fireplace 00 N/A
 Res Fixtures 0006 06 Fixtures
 Garage
 Integral Garage
 Remodeling Adj 04 1/2 - 3/4 U
 Actual Year Blt 1870
 Effect Year Blt 1870
 Cond/Desir/Util F Res CDU - F
 Township Multpl 06 TOWNSHIP #0
 Funct. Obs. % 000000
 Economic Obs. % 000000
 Observed Cond % 000000
 Obs. Cond. Code
 Combination A
 Comb A Ht/AC
 Unfin Low/Level
 Full Basement
 # Of Bedrooms 04 Four Bedroo
 Sq.Ft.Grnd Area 1104

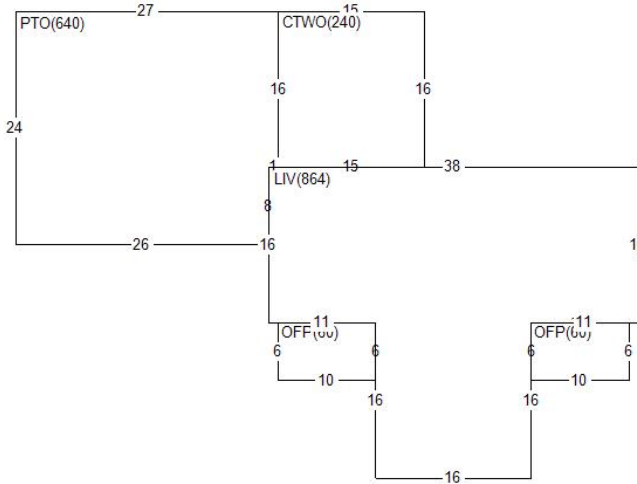

Land Value 15,000
 Misc Value 10,040
 Bldg Value 83,870
 Total Value 108,910
 Value By CAMA

RCN 178,453
 Pct Good 0.4700
 Obsol/Observed 0.0000
 Building Value 83,870

| DOCUMENT # | DATE | QS | SALE PRICE |
|------------|------|------|------------|
| 393052 | 1117 | U | |
| 356973 | 0612 | U | |
| 355480 | 0412 | U | |
| PERMIT NO | TYPE | DATE | AMOUNT |
| 10626 | 31 | 0802 | |

Appraiser JB J. Brown
 Appr Date 07/22/22
 Use Code 0040 Imp Res
 NBHD 1900.30 FLD PLN PRIOR/40
 L100 M100 B144

| AREA | FLAT | EFF% | E/AREA | ACT% | A/AREA | EA/AA | HEATED |
|------|------|------|--------|------|--------|-------|--------|
| LIV | 864 | 1.00 | 864 | 1.00 | 864 | 864 | 864 |
| OFF | 120 | 1.00 | 120 | 1.00 | 120 | 120 | |
| PTO | 640 | 1.00 | 640 | 1.00 | 640 | 640 | |
| CTWO | 240 | 1.00 | 240 | 1.00 | 240 | 240 | |
| CRWL | 864 | 1.00 | 864 | 1.00 | 864 | 864 | |

| MISC BLDG CODE | DESC | LENGTH | WIDTH | UNITS | ADJ PRICE | EYB DT PCT | ADJUSTMENT | VALUE |
|----------------|----------------------|--------|-------|---------|------------|---------------|-------------|--------|
| 1 1 OFP | Open Frame Porch | 6.00 | 10.00 | 60.00 | 32.50 | 1920 F 53.00 | 1.00 | 920 |
| 2 1 OFP | Open Frame Porch | 6.00 | 10.00 | 60.00 | 32.50 | 1920 F 53.00 | 1.00 | 920 |
| 3 4 GARF | Garage Frame | 26.00 | 12.00 | 312.00 | 15.74 | 1975 P 53.00 | .82 | 2,310 |
| 4 3 SHED | Frame Shed | .00 | .00 | 144.00 | 26.53 | 1975 F 49.00 | 1.00 | 1,950 |
| 6 1 PTO | Concrete Patio | .00 | .00 | 640.00 | 3.65 | 1999 A 14.00 | 1.00 | 2,010 |
| 7 1 FRBLDGS | Frame Bldgs | 26.00 | 22.00 | 572.00 | 7.39 | 1994 20 85.00 | 1.00 | 630 |
| LAND LUSE DESC | ZONING | UNITS | TP | PRICE | ADJUSTMENT | CODE/FACTOR | ADJUSTMENT | VALUE |
| 1 CK | County Road Cat. MAL | 5.00 | R | 3000.00 | .00 | .00 | .00 TW 1.00 | 15,000 |

Req By: KRIS_K
BRENDAN PRUETT
9746 B RD

| MISC | BLDG CODE | DESC | Site Address: | COLUMBIA | B | IL 62236 | RD | ADJ PRICE | EYB DT | PCT | ADJUSTMENT | VALUE |
|------|-----------|-------------|---------------|----------|---------|----------|----|-----------|---------|-------|------------|-------|
| 8 | 2 | FRBLDGS | 009746 | | | | | 7.39 | 1984 20 | 85.00 | 1.00 | 1,300 |
| | | Frame Bldgs | LENGTH | WIDTH | UNITS | | | | | | | |
| | | | 39.00 | 30.00 | 1170.00 | | | | | | | |