

Req By: KRIS_K
MATTHEW KIRKWOOD &
MELISSA MENSE
1457 MERRIMAC RD

LOT 9C PART SW SW

VALMEYER IL 62295

Site Address: 001457 MERRIMAC RD

BLDG # 1
 Style/Stories 1.5 1 1/2 Story
 Quality/Design C C-Average
 Building Use 0100 Single Fami
 Exterior Wall F Frame 1.5
 WALL % 100 100%
 Exterior Wall 1
 WALL 1% 000 N/A
 Crawl Sp. Adj C Crawl
 Slab Adjustment
 Basement
 Combination F1 Frame/1.0
 Attic Area
 Heat/AC Adj AC Central Air
 Comb Ht/AC Adj AC1 Cent AC Cmb
 Fireplace 00 N/A
 Extra Fireplace 00 N/A
 Res Fixtures 0005 05 Fixtures
 Garage
 Integral Garage
 Remodeling Adj 05 Complete Re
 Actual Year Blt 1943
 Effect Year Blt 1943
 Cond/Desir/Util A Res CDU - A
 Township Multpl 06 TOWNSHIP #0
 Funct. Obs. % 000000
 Economic Obs. % 000000
 Observed Cond % 000000
 Obs. Cond. Code
 Combination A
 Comb A Ht/AC
 Unfin Low/Level
 Full Basement
 # Of Bedrooms 04 Four Bedroo
 Sq.Ft.Grd Area 1358

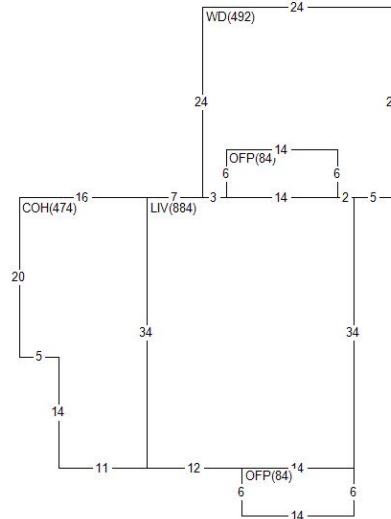

Land Value 8,460
 Misc Value 27,920
 Bldg Value 99,420
 Total Value 135,800
 Value By CAMA

RCN 180,763
 Pct Good 0.5500
 Obsol/Observed 0.0000
 Building Value 99,420

DOCUMENT #	DATE	QS	SALE PRICE
420510	1021	Q	138,000
412248	1120	Q	102,700
383124	0516	U	95,000

PERMIT NO	TYPE	DATE	AMOUNT

Appraiser KS K. Sondag
 Appr Date 07/27/22
 Use Code 0040 Imp Res
 NBHD 1900.20 FLD PLN 40-59
 L100 M100 B144

AREA	FLAT	EFF% E/AREA	ACT% A/AREA	EA/AA HEATED
LIV	884	1.00	884	884
COH	474	1.00	474	474
OFF	168	1.00	168	168
WD	492	1.00	492	492
CRWL	1358	1.00	1358	1358

MISC BLDG CODE	DESC	LENGTH	WIDTH	UNITS	ADJ PRICE	EYB DT PCT	ADJUSTMENT	VALUE
2 1 OFP	Open Frame Porch	6.00	14.00	84.00	28.90	1984 A 29.00	1.00	1,720
3 1 OFP	Open Frame Porch	6.00	14.00	84.00	28.90	1984 A 29.00	1.00	1,720
4 1 WD	Wood Deck	.00	.00	492.00	19.35	2007 F 15.00	1.00	8,090
5 1 SHED	Frame Shed	10.00	12.00	120.00	26.61	2003 A 11.00	1.00	2,840
6 1 SHED	Frame Shed	28.00	32.00	896.00	18.67	1994 A 19.00	.82	13,550

LAND LUSE DESC	ZONING	UNITS TP	PRICE	ADJUSTMENT	CODE/FACTOR	VALUE
1 CK County Road Cat.	MAL	2.82 R	3000.00	.00	.00 TW 1.00	8,460