

Req By: KRIS_K
 DANIEL O RAHE TRUST &
 BRENDA L RAHE TRUST
 9013 BLUFF RD

PART LOT 2 SUR 428

WATERLOO IL 62298

Site Address: 009013 BLUFF RD

BLDG # 1
 Style/Stories 2.0 2 Story
 Quality/Design C C-Average
 Building Use 0100 Single Fami
 Exterior Wall F Frame 2.0
 WALL % 100 100%
 Exterior Wall 1
 WALL 1% 000 N/A
 Crawl Sp. Adj
 Slab Adjustment
 Basement
 Combination F1 Frame/1.0
 Attic Area
 Heat/AC Adj AC Central Air
 Comb Ht/AC Adj AC1 Cent AC Cmb
 Fireplace 00 N/A
 Extra Fireplace 00 N/A
 Res Fixtures 0015 15 Fixtures
 Garage
 Integral Garage
 Remodeling Adj 01 No Remodeli
 Actual Year Blt 1994
 Effect Year Blt 1994
 Cond/Desir/Util A Res CDU - A
 Township Multpl 06 TOWNSHIP #0
 Funct. Obs. % 000010
 Economic Obs. % 000010
 Observed Cond % 000000
 Obs. Cond. Code
 Combination A
 Comb A Ht/AC
 Unfin Low/Level
 Full Basement F Full Baseme
 # Of Bedrooms 03 Three Bedro
 Sq.Ft.Grnd Area 1976

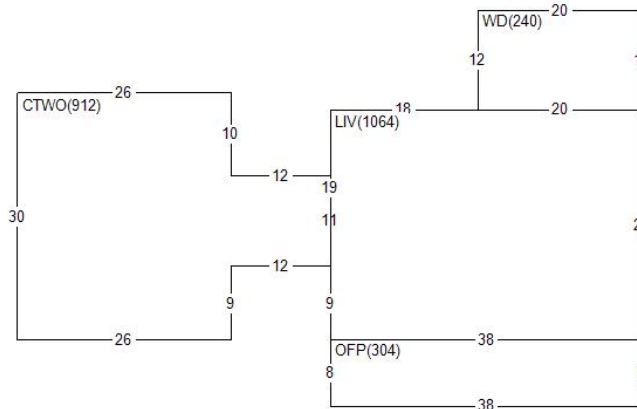

Land Value 7,500
 Misc Value 0
 Bldg Value 242,500
 Total Value 250,000
 Value By Override

RCN 344,168
 Pct Good 0.8100
 Obsol/Observed 0.2000
 Building Value 209,940

DOCUMENT #	DATE	QS	SALE PRICE
426552	1022	U	
	0494	07	4,000

PERMIT NO	TYPE	DATE	AMOUNT
NOR	99	0816	
10432	09	0202	
8913	00	0897	

Appraiser AS A. Schwar
 Appr Date 11/09/22
 Use Code 0040 Imp Res
 NBHD 1900.10 FLD PLN 60-NEW
 L100 M100 B170

AREA	FLAT	EFF% E/AREA	ACT% A/AREA	EA/AA	HEATED
OFF	304	1.00	304	1.00	304
CTWO	912	1.00	912	1.00	912
WD	240	1.00	240	1.00	240
LIV	1064	1.00	1064	1.00	1064
SHED	120	1.00	120	1.00	120

MISC BLDG CODE	DESC	LENGTH	WIDTH	UNITS	ADJ PRICE	EYB DT	PCT	ADJUSTMENT	VALUE	
1 1	OFFP	Open Frame Porch	8.00	38.00	304.00	22.79	1994 A	19.00	1.00	5,610
3 1	WD	Wood Deck	12.00	20.00	240.00	19.35	1994 A	19.00	1.00	3,760
4 1	ASP	Asphalt Driveway	1988.00	12.00	23856.00	2.85	2019 A	1.00	1.00	67,310

LAND LUSE DESC	ZONING	UNITS TP	PRICE	ADJUSTMENT	CODE/FACTOR	VALUE	
1 CK County Road Cat.	MA1	2.50 R	3000.00	.00	.00 TW	1.00	7,500