

LOT 3 EAGLE CLIFF ESTATES

WATERLOO IL 62298

Site Address: 002314 CONDOR CT

BLDG # 1
 Style/Stories 1.0 One Story
 Quality/Design C C-Average
 Building Use 0100 Single Fami
 Exterior Wall F Frame
 WALL % 100 100%
 Exterior Wall 1
 WALL 1% 000 N/A
 Crawl Sp. Adj
 Slab Adjustment
 Basement RC C-Rec Room
 Combination
 Attic Area
 Heat/AC Adj AC Central Air
 Comb Ht/AC Adj
 Fireplace 03 C-Fireplace
 Extra Fireplace 00 N/A
 Res Fixtures 0012 12 Fixtures
 Garage F Frame Garag
 Integral Garage
 Remodeling Adj 01 No Remodeli
 Actual Year Blt 2015
 Effect Year Blt 2015
 Cond/Desir/Util A
 Township Multpl 06 TOWNSHIP #0
 Funct. Obs. % 000000
 Economic Obs. % 000000
 Observed Cond % 000000
 Obs. Cond. Code
 Combination A
 Comb A Ht/AC
 Unfin Low/Level
 Full Basement F Full Baseme
 # Of Bedrooms 03 Three Bedro
 Sq.Ft.Grđ Area 2016

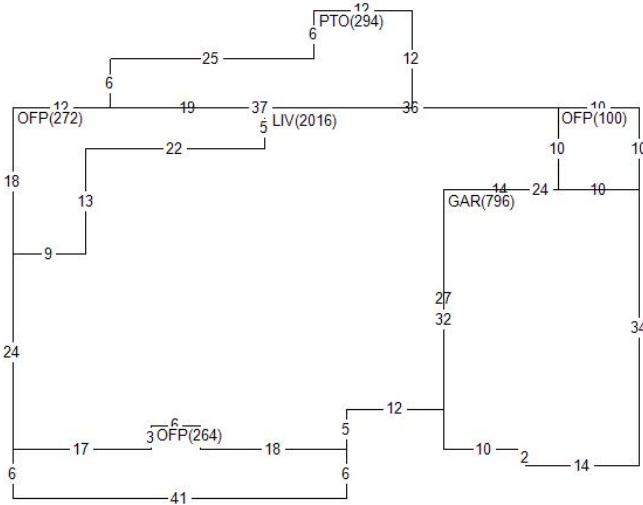

Land Value 73,410
 Misc Value 39,110
 Bldg Value 332,860
 Total Value 445,380
 Value By CAMA

RCN 339,656
 Pct Good 0.9800
 Obsol/Observed 0.0000
 Building Value 332,860

DOCUMENT #	DATE	QS	SALE PRICE
382956	0416	04	
375064	0115	Q	60,000
341414	0710	U	66,750
PERMIT NO	TYPE	DATE	AMOUNT
13782	00	0915	
13782	01	0315	

Appraiser KS K. Sondag
 Appr Date 08/02/22
 Use Code 0040 Imp Res
 NBHD 709.08 6/7&8 1.0 10/NEW
 L100 M100 B200

AREA	FLAT	EFF% E/AREA	ACT% A/AREA	EA/AA HEATED
LIV	2016	1.00	2016 1.00	2016 2016 2016
OFF	636	1.00	636 1.00	636 636
PTO	294	1.00	294 1.00	294 294
GAR	796	1.00	796 1.00	796 796
CONDR	2075	1.00	2075 1.00	2075 2075
BSMR	708	1.00	708 1.00	708 708

MISC BLDG CODE	DESC	LENGTH	WIDTH	UNITS	ADJ PRICE	EYB DT PCT	ADJUSTMENT	VALUE
1 1	OFFP Open Frame Porch	.00	.00	264.00	23.53	2015 A 2.00	1.00	6,090
2 1	OFFP Open Frame Porch	.00	.00	272.00	23.37	2015 A 2.00	1.00	6,230
3 1	OFFP Open Frame Porch	10.00	10.00	100.00	27.00	2015 A 2.00	1.00	2,650
4 1	PTO Concrete Patio	.00	.00	294.00	3.65	2015 A 2.00	1.00	1,050
5 1	CONDR Concrete Drivewa	.00	.00	2075.00	3.65	2015 A 2.00	1.00	7,420
6 1	PS4C10 Pole Shd 4 Sde C	32.00	24.00	768.00	16.12	2015 20 34.00	1.00	8,170
LAND LUSE DESC	ZONING	UNITS TP	PRICE	ADJUSTMENT	CODE/FACTOR	ADJUSTMENT	VALUE	
1 CJ	County Road Cat. MAL	5.50 R	13346.40	TW 1.00	.00	.00	.00	73,410

			WATERLOO			IL 62298					
			Site Address: 002314			CONDOR			CT		
MISC	BLDG CODE	DESC	LENGTH	WIDTH	UNITS	ADJ PRICE	EYB DT	PCT	ADJUSTMENT	VALUE	
7	2 LTP	Lean-to Pole	32.00	6.00	192.00	8.64	2015 20	34.00	1.00	1,100	
8	1 SHED	Frame Shed	8.00	9.00	72.00	26.77	2019 A	1.00	1.00	1,910	
9	1 SHED	Frame Shed	10.00	10.00	100.00	26.67	2019 A	1.00	1.00	2,640	
10	1 PSCFL	Pole Shd Conc Fl	32.00	24.00	768.00	3.65	2015 20	34.00	1.00	1,850	