

PART LOT 1 EAGLE CLIFF ESTATES

WATERLOO IL 62298
Site Address: 002303 CONDOR CT

BLDG # 1
 Style/Stories 1.0 One Story
 Quality/Design C C-Average
 Building Use 0100 Single Fami
 Exterior Wall F Frame
 WALL % 100 100%
 Exterior Wall 1
 WALL 1% 000 N/A
 Crawl Sp. Adj
 Slab Adjustment
 Basement
 Combination
 Attic Area
 Heat/AC Adj AC Central Air
 Comb Ht/AC Adj
 Fireplace C-Fireplace
 Extra Fireplace 00 N/A
 Res Fixtures 0012 12 Fixtures
 Garage F Frame Garag
 Integral Garage
 Remodeling Adj 01 No Remodeli
 Actual Year Blt 2011
 Effect Year Blt 2011
 Cond/Desir/Util A
 Township Multpl 06 TOWNSHIP #0
 Funct. Obs. %
 Economic Obs. %
 Observed Cond %
 Obs. Cond. Code
 Combination A
 Comb A Ht/AC
 Unfin Low/Level
 Full Basement F Full Baseme
 # Of Bedrooms 02 Two Bedroom
 Sq.Ft.Grđ Area 2183

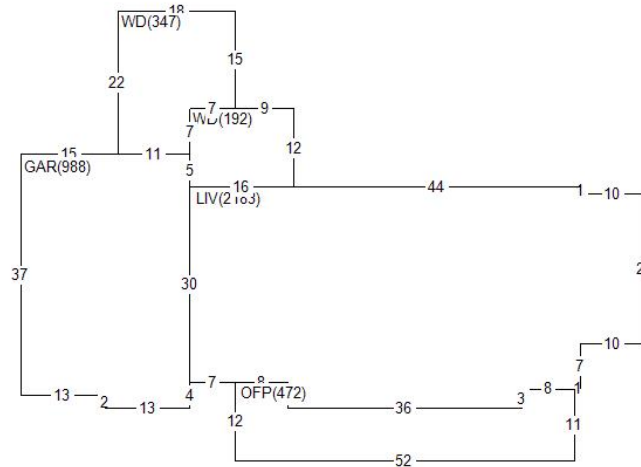

Land Value 85,210
 Misc Value 60,230
 Bldg Value 339,850
 Total Value 485,290
 Value By CAMA

RCN 357,734
 Pct Good 0.9500
 Obsol/Observed 0.0000
 Building Value 339,850

DOCUMENT #	DATE	QS	SALE PRICE
367899	1013	Q	350,000
	0301	Q	89,000

PERMIT NO	TYPE	DATE	AMOUNT
14800	04	1118	
14241	00	0617	
14275	02	0217	

Appraiser JB J. Brown
 Appr Date 08/05/22
 Use Code 0040 Imp Res
 NBHD 709.08 6/7&8 1.0 10/NEW
 L100 M100 B200

	AREA	FLAT	EFF% E/AREA	ACT% A/AREA	EA/AA	HEATED
CONDR	888	888	1.00	888	1.00	888
LIV	2183	2183	1.00	2183	1.00	2183
WD	539	539	1.00	539	1.00	539
GAR	988	988	1.00	988	1.00	988
OFP	472	472	1.00	472	1.00	472

MISC BLDG CODE	DESC	LENGTH	WIDTH	UNITS	ADJ PRICE	EYB DT PCT	ADJUSTMENT	VALUE
1	1 OFP	Open Frame Porch	.00	.00	472.00	21.29 2011 A 5.00	1.00	9,550
2	1 WD	Wood Deck	12.00	16.00	192.00	19.35 2011 A 5.00	1.00	3,530
3	1 CONDR	Concrete Drivewa	24.00	37.00	888.00	3.65 2011 A 5.00	1.00	3,080
4	1 DORM	Dormer	.00	.00	1.00	1850.00 2011 OD 0.00	1.00	1,850
6	1 OFP	Open Frame Porch	8.00	10.00	80.00	29.38 2014 A 3.00	1.00	2,280
7	1 CONDR	Concrete Drivewa	20.00	37.00	740.00	3.65 2014 A 3.00	1.00	2,620
LAND LUSE DESC	ZONING	UNITS TP	PRICE	ADJUSTMENT CODE/FACTOR			VALUE	
1 CJ	County Road Cat. MAL	7.83 R	10883.05	.00	.00	.00 TW	1.00	85,210

Req By: KRIS_K
 JOHN P & CAROLE A CRUM
 2303 CONDOR CT

			WATERLOO			IL 62298					
			Site Address: 002303			CONDOR			CT		
MISC	BLDG CODE	DESC	LENGTH	WIDTH	UNITS	ADJ PRICE	EYB DT	PCT	ADJUSTMENT	VALUE	
8	1	WD	.00	.00	147.00	19.35	2015 A	2.00	1.00	2,790	
9	1	PTO	.00	.00	346.00	2.99	2015 A	2.00	.82	1,020	
10	1	SHED	12.00	20.00	240.00	26.20	2017 A	2.00	1.00	6,160	
11	1	PS4C10	36.00	48.00	1728.00	12.53	2014 20	38.25	1.00	13,370	
12	2	PSCFL	30.00	36.00	1080.00	3.65	2016 20	29.75	1.00	2,770	
13	2	PS4C12	30.00	36.00	1080.00	14.78	2016 20	29.75	1.00	11,210	