

LOT 7 EAGLE CLIFF ESTATES

WATERLOO IL 62298

Site Address: 002301 GOLDEN EAGLE DR

BLDG # 1  
 Style/Stories 1.0 One Story  
 Quality/Design C C-Average  
 Building Use 0100 Single Fami  
 Exterior Wall F Frame  
 WALL % 100 100%  
 Exterior Wall 1  
 WALL 1% 000 N/A  
 Crawl Sp. Adj  
 Slab Adjustment  
 Basement  
 Combination F2 Frame/2.0  
 Attic Area  
 Heat/AC Adj AC Central Air  
 Comb Ht/AC Adj AC2 Cent AC Cmb  
 Fireplace 00 N/A  
 Extra Fireplace 00 N/A  
 Res Fixtures 0011 11 Fixtures  
 Garage F Frame Garag  
 Integral Garage  
 Remodeling Adj 01 No Remodeli  
 Actual Year Blt 2013  
 Effect Year Blt 2013  
 Cond/Desir/Util A Res CDU - A  
 Township Multpl 06 TOWNSHIP #0  
 Funct. Obs. % 000000  
 Economic Obs. % 000000  
 Observed Cond % 000000  
 Obs. Cond. Code  
 Combination A  
 Comb A Ht/AC  
 Unfin Low/Level  
 Full Basement F Full Baseme  
 # Of Bedrooms 02 Two Bedroom  
 Sq.Ft.Grd Area 2132

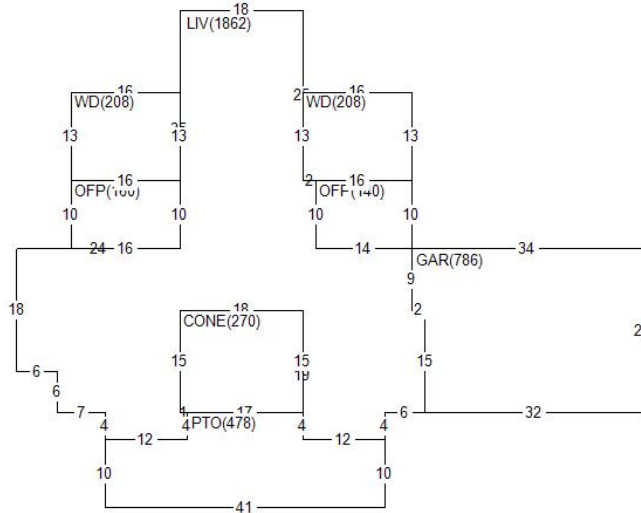

Land Value 58,240  
 Misc Value 44,060  
 Bldg Value 350,270  
 Total Value 452,570  
 Value By CAMA

RCN 361,098  
 Pct Good 0.9700  
 Obsol/Observed 0.0000  
 Building Value 350,270

DOCUMENT # DATE QS SALE PRICE  
 0102 Q 100,000

PERMIT NO TYPE DATE AMOUNT  
 13410 02 0813  
 12739 00 0112  
 12739 01 0610  
 Appraiser KS K. Sondag  
 Apr Date 08/02/22  
 Use Code 0040 Imp Res  
 NBHD 709.08 6/7&8 1.0 10/NEW  
 L100 M100 B200

| AREA  | FLAT | EFF% E/AREA | ACT% A/AREA | EA/AA HEATED |
|-------|------|-------------|-------------|--------------|
| LIV   | 1862 | 1.00        | 1862 1.00   | 1862 1862    |
| CONE  | 270  | 1.00        | 270 1.00    | 270 270      |
| PTO   | 478  | 1.00        | 478 1.00    | 478 478      |
| OFFP  | 300  | 1.00        | 300 1.00    | 300 300      |
| WD    | 416  | 1.00        | 416 1.00    | 416 416      |
| GAR   | 786  | 1.00        | 786 1.00    | 786 786      |
| CONDR | 713  | 1.00        | 713 1.00    | 713 713      |

| MISC BLDG CODE | DESC             | LENGTH | WIDTH | UNITS  | ADJ PRICE | EYB DT PCT  | ADJUSTMENT | VALUE |
|----------------|------------------|--------|-------|--------|-----------|-------------|------------|-------|
| 1 1 CONDR      | Concrete Drivewa | .00    | .00   | 713.00 | 3.65      | 2013 A 3.00 | 1.00       | 2,520 |
| 2 1 PTO        | Concrete Patio   | .00    | .00   | 478.00 | 3.65      | 2013 A 3.00 | 1.00       | 1,690 |
| 3 1 OFFP       | Open Frame Porch | 10.00  | 16.00 | 160.00 | 23.77     | 2013 A 3.00 | 1.00       | 3,690 |
| 4 1 OFFP       | Open Frame Porch | 10.00  | 14.00 | 140.00 | 24.48     | 2013 A 3.00 | 1.00       | 3,320 |
| 5 1 WD         | Wood Deck        | 13.00  | 16.00 | 208.00 | 19.35     | 2013 A 3.00 | 1.00       | 3,900 |
| 6 1 WD         | Wood Deck        | 13.00  | 16.00 | 208.00 | 19.35     | 2013 A 3.00 | 1.00       | 3,900 |

| LAND LUSE DESC        | ZONING | UNITS TP | PRICE    | ADJUSTMENT     | CODE/FACTOR | VALUE  |
|-----------------------|--------|----------|----------|----------------|-------------|--------|
| 1 CJ County Road Cat. | MAL    | 1.74 R   | 31234.78 | .00            | .00 TW 1.00 | 54,350 |
| 2 CJ County Road Cat. | MAL    | 6.35 R   | 12238.30 | TW 1.00 CN .05 | .00 .00     | 3,890  |

| MISC BLDG CODE |          | DESC             | Site Address: 002301 |       | UNITS   | ADJ PRICE | EYB DT  | PCT   | ADJUSTMENT | VALUE  |
|----------------|----------|------------------|----------------------|-------|---------|-----------|---------|-------|------------|--------|
|                |          |                  | LENGTH               | WIDTH |         |           |         |       |            |        |
| 7              | 1 BRVEN  | Brick Veneer     | .00                  | .00   | 456.00  | 14.65     | 2013 A  | 3.00  | 1.00       | 6,480  |
| 8              | 1 PS4C14 | Pole Shd 4 Sde C | 42.00                | 54.00 | 2268.00 | 13.25     | 2014 20 | 38.25 | 1.00       | 18,560 |