

LOT 6 EAGLE CLIFF ESTATES

WATERLOO IL 62298
 Site Address: 002339 GOLDEN EAGLE LN

BLDG # 1
 Style/Stories 1.5 1 1/2 Story
 Quality/Design C C-Average
 Building Use 0100 Single Fami
 Exterior Wall F Frame 1.5
 WALL % 100 100%
 Exterior Wall 1
 WALL 1% 000 N/A
 Crawl Sp. Adj
 Slab Adjustment
 Basement
 Combination F1 Frame/1.0
 Attic Area UFA UNFINISHED
 Heat/AC Adj AC Central Air
 Comb Ht/AC Adj AC1 Cent AC Cmb
 Fireplace 03 C-Fireplace
 Extra Fireplace 00 N/A
 Res Fixtures 0011 11 Fixtures
 Garage F Frame Garag
 Integral Garage
 Remodeling Adj 01 No Remodeli
 Actual Year Blt 1999
 Effect Year Blt 1999
 Cond/Desir/Util A Res CDU - A
 Township Multpl 06 TOWNSHIP #0
 Funct. Obs. % 000000
 Economic Obs. % 000000
 Observed Cond % 000000
 Obs. Cond. Code
 Combination A
 Comb A Ht/AC UFA 286 1.00 286 1.00 286 286
 Unfin Low/Level LIV 1152 1.00 1152 1.00 1152 1152 1152
 Full Basement F Full Baseme COH 245 1.00 245 1.00 245 245
 # Of Bedrooms 03 Three Bedro OFP 480 1.00 480 1.00 480 480
 Sq.Ft.Grđ Area 1397 GAR 572 1.00 572 1.00 572 572
 WD 740 1.00 740 1.00 740 740

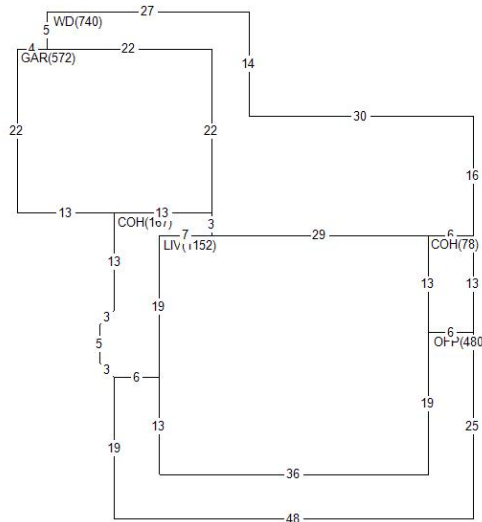

Land Value 70,720
 Misc Value 20,080
 Bldg Value 302,790
 Total Value 393,590
 Value By CAMA

RCN 352,076
 Pct Good 0.8600
 Obsol/Observed 0.0000
 Building Value 302,790

DOCUMENT #	DATE	QS	SALE PRICE
	0892	Q	16,500
	0391	Q	15,875

PERMIT NO	TYPE	DATE	AMOUNT
8995	00	0399	
8995	01	0997	

Appraiser KS K. Sondag
 Appr Date 08/02/22
 Use Code 0040 Imp Res
 NBHD 709.15 6/7&8 1.5 40/NEW
 L100 M100 B202

MISC BLDG CODE	DESC	LENGTH	WIDTH	UNITS	ADJ PRICE	EYB DT PCT	ADJUSTMENT	VALUE
1 1 OFP	Open Frame Porch	.00	.00	480.00	21.24	1999 A 14.00	1.00	8,770
2 1 WD	Wood Deck	.00	.00	740.00	19.35	2000 F 21.00	1.00	11,310

LAND LUSE DESC	ZONING	UNITS TP	PRICE	ADJUSTMENT CODE/FACTOR	VALUE
1 CJ County Road Cat.	MA1	4.97 R	14229.18	.00 .00 .00 TW 1.00	70,720