

Req By: KRIS_K
STACY C ACKERMANN
2425 FALCON PLACE

LOT 19 & ROADWAY KNOWN AS FALCON
PLACE - EAGLE CLIFF ESTATES

WATERLOO IL 62298

Site Address: 002425 FALCON PL

BLDG # 1
 Style/Stories 1.0 One Story
 Quality/Design C C-Average
 Building Use 0100 Single Fami
 Exterior Wall F Frame
 WALL % 100 100%
 Exterior Wall 1
 WALL 1% 000 N/A
 Crawl Sp. Adj
 Slab Adjustment
 Basement RC C-Rec Room
 Combination
 Attic Area
 Heat/AC Adj AC Central Air
 Comb Ht/AC Adj
 Fireplace 31 DirectVent
 Extra Fireplace 00 N/A
 Res Fixtures 0014 14 Fixtures
 Garage F Frame Garag
 Integral Garage
 Remodeling Adj 01 No Remodeli
 Actual Year Blt 2018
 Effect Year Blt 2018
 Cond/Desir/Util A Res CDU - A
 Township Multpl 06 TOWNSHIP #0
 Funct. Obs. % 000000
 Economic Obs. % 000000
 Observed Cond % 000000
 Obs. Cond. Code
 Combination A
 Comb A Ht/AC
 Unfin Low/Level
 Full Basement F Full Baseme
 # Of Bedrooms 03 Three Bedro
 Sq.Ft.Grd Area 1943

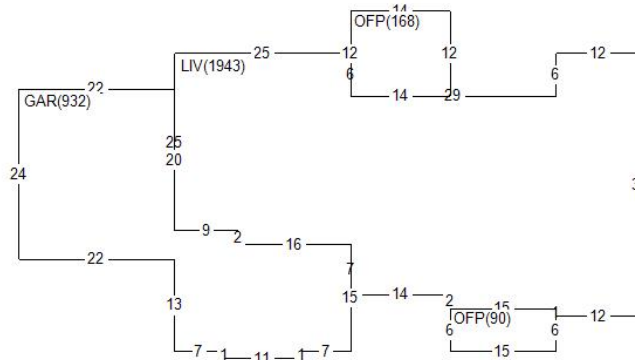

Land Value 73,560
 Misc Value 13,890
 Bldg Value 341,170
 Total Value 428,620
 Value By CAMA

RCN 344,620
 Pct Good 0.9900
 Obsol/Observed 0.0000
 Building Value 341,170

DOCUMENT #	DATE	QS	SALE PRICE
412015	1020	U	
394689	0318	Q	353,331
390451	0617	Q	55,000
PERMIT NO	TYPE	DATE	AMOUNT
14402	00	0318	
14402	01	0817	

Appraiser JB J. Brown
 Appr Date 08/05/22
 Use Code 0040 Imp Res
 NBHD 709.08 6/7&8 1.0 10/NEW
 L100 M100 B200

AREA	FLAT	EFF% E/AREA	ACT% A/AREA	EA/AA	HEATED
LIV	1943	1.00	1943	1.00	1943
OFFP	258	1.00	258	1.00	258
GAR	932	1.00	932	1.00	932
CONDR	942	1.00	942	1.00	942
BSMR	971	1.00	971	1.00	971

MISC BLDG CODE	DESC	LENGTH	WIDTH	UNITS	ADJ PRICE	EYB DT	PCT	ADJUSTMENT	VALUE
1 1 OFFP	Open Frame Porch	6.00	15.00	90.00	28.19	2018 A	1.00	1.00	2,510
2 1 OFFP	Open Frame Porch	12.00	14.00	168.00	23.59	2018 A	1.00	1.00	3,920
3 1 CONDR	Concrete Drivewa	.00	.00	942.00	3.65	2018 A	1.00	1.00	3,400
4 1 BRVEN	Brick Veneer	.00	.00	280.00	14.65	2018 A	1.00	1.00	4,060

LAND LUSE DESC	ZONING	UNITS TP	PRICE	ADJUSTMENT	CODE/FACTOR	VALUE
1 CJ County Road Cat.	MA1	5.53 R	13301.49	TW 1.00	.00 .00	73,560