

PART S 1/2 SE

WATERLOO IL 62298

Site Address: 006848 D RD

BLDG # 1  
 Style/Stories 1.0 One Story  
 Quality/Design C C-Average  
 Building Use 0100 Single Fami  
 Exterior Wall F Frame  
 WALL % 100 100%  
 Exterior Wall 1  
 WALL 1% 000 N/A  
 Crawl Sp. Adj  
 Slab Adjustment  
 Basement RC C-Rec Room  
 Combination  
 Attic Area  
 Heat/AC Adj AC Central Air  
 Comb Ht/AC Adj  
 Fireplace 03 C-Fireplace  
 Extra Fireplace 00 N/A  
 Res Fixtures 0014 14 Fixtures  
 Garage F Frame Garag  
 Integral Garage  
 Remodeling Adj 01 No Remodeli  
 Actual Year Blt 2005  
 Effect Year Blt 2005  
 Cond/Desir/Util A  
 Township Multpl 06  
 Funct. Obs. %  
 Economic Obs. %  
 Observed Cond %  
 Obs. Cond. Code  
 Combination A  
 Comb A Ht/AC  
 Unfin Low/Level  
 Full Basement F Full Baseme  
 # Of Bedrooms 03 Three Bedro  
 Sq.Ft.Grd Area 2182

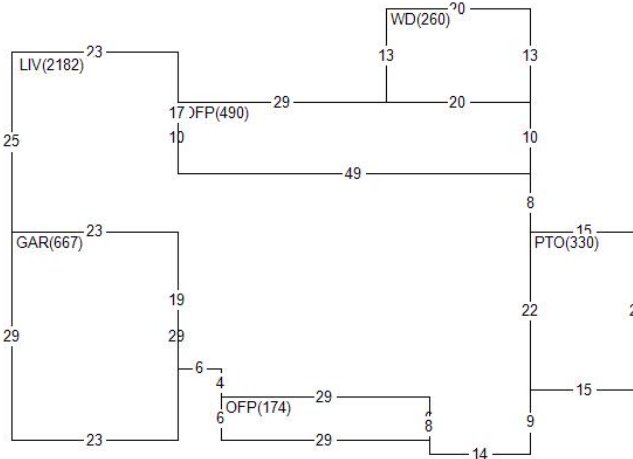

Land Value 58,200  
 Misc Value 50,540  
 Bldg Value 336,040  
 Total Value 444,780  
 Value By CAMA

RCN 369,272  
 Pct Good 0.9100  
 Obsol/Observed 0.0000  
 Building Value 336,040

DOCUMENT #	DATE	QS	SALE PRICE
286181	0404	Q	60,000
265631	1102	U	

PERMIT NO	TYPE	DATE	AMOUNT
15671	00	0921	
15671	05	0821	
11473	00	0805	

Appraiser JB J. Brown  
 Appr Date 08/05/22  
 Use Code 0011 Imp. Farm  
 NBHD 709.08 6/7&8 1.0 10/NEW  
 L100 M100 B200

AREA	FLAT	EFF% E/AREA	ACT% A/AREA	EA/AA HEATED
CONDR	1176	1.00	1176	1176
BSMR	1320	1.00	1320	1320
OFFP	664	1.00	664	664
GAR	667	1.00	667	667
PTO	330	1.00	330	330
LIV	2182	1.00	2182	2182
WD	260	1.00	260	260

MISC BLDG CODE	DESC	LENGTH	WIDTH	UNITS	ADJ PRICE	EYB DT PCT	ADJUSTMENT	VALUE
2 1 OFFP	Open Frame Porch	6.00	29.00	174.00	23.45	2005 A 9.00	1.00	3,710
3 1 OFFP	Open Frame Porch	10.00	49.00	490.00	21.17	2005 A 9.00	1.00	9,440
4 1 CONDR	Concrete Drivewa	.00	.00	1176.00	3.65	2005 A 9.00	1.00	3,910
5 1 PTO	Concrete Patio	15.00	22.00	330.00	3.65	2007 A 7.00	1.00	1,120
6 1 DORM	Dormer	.00	.00	2.00	1850.00	2005 OD 0.00	1.00	3,700
7 1 WD	Wood Deck	13.00	20.00	260.00	19.35	2015 A 2.00	1.00	4,930
LAND LUSE DESC	ZONING	UNITS TP	PRICE	ADJUSTMENT	CODE/FACTOR	ADJUSTMENT	VALUE	
1 CJ County Road Cat.	MA1	2.50 R	23280.16	TW 1.00	.00	.00	58,200	

Req By: KRIS\_K  
 PATRICK & JANE MCCARTHY  
 6848 D RD

			WATERLOO		IL 62298						
Site Address: 006848			D		RD						
MISC	BLDG CODE	DESC	LENGTH	WIDTH	UNITS	ADJ PRICE	EYB DT	PCT	ADJUSTMENT	VALUE	
8	2	GARF	32.00	24.00	768.00	19.22	2015 A	2.00	1.00	14,470	
9	3	PS4C10	48.00	30.00	1440.00	12.80	2005 20	76.50	1.00	4,330	
10	3	PSCFL	30.00	30.00	900.00	3.65	2005 20	76.50	1.00	770	
11	3	AC	30.00	30.00	900.00	2.69	2005 20	76.50	1.00	570	
12	3	HEAT	30.00	30.00	900.00	4.61	2005 20	76.50	1.00	980	
13	4	CPTMTL	40.00	20.00	800.00	3.26	2021 A	0.00	1.00	2,610	