

PART LOT 2

VALMEYER IL 62295

Site Address: 001848 ZIEBOLD RD

BLDG # 1  
 Style/Stories 1.0 One Story  
 Quality/Design C C-Average  
 Building Use 0100 Single Fami  
 Exterior Wall F Frame  
 WALL % 100 100%  
 Exterior Wall 1  
 WALL 1% 000 N/A  
 Crawl Sp. Adj C Crawl  
 Slab Adjustment  
 Basement  
 Combination F2 Frame/2.0  
 Attic Area  
 Heat/AC Adj AC Central Air  
 Comb Ht/AC Adj AC2 Cent AC Cmb  
 Fireplace 00 N/A  
 Extra Fireplace 00 N/A  
 Res Fixtures 0011 11 Fixtures  
 Garage  
 Integral Garage  
 Remodeling Adj 04 1/2 - 3/4 U  
 Actual Year Blt 1883  
 Effect Year Blt 1883  
 Cond/Desir/Util A Res CDU - A  
 Township Multpl 06 TOWNSHIP #0  
 Funct. Obs. % 000000  
 Economic Obs. % 000000  
 Observed Cond % 000000  
 Obs. Cond. Code  
 Combination A  
 Comb A Ht/AC  
 Unfin Low/Level  
 Full Basement  
 # Of Bedrooms 03 Three Bedro  
 Sq.Ft.Gr'd Area 1696

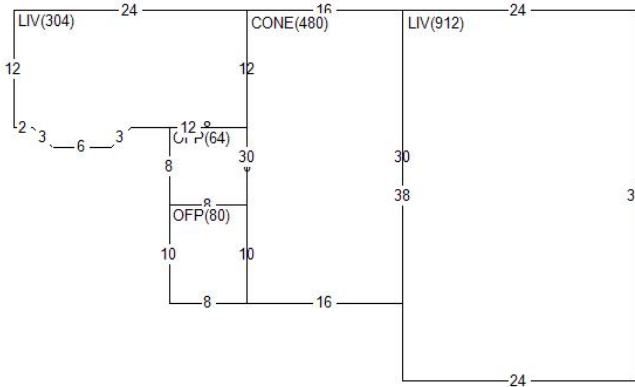

Land Value 15,000  
 Misc Value 18,230  
 Bldg Value 116,020  
 Total Value 149,250  
 Value By CAMA

RCN 210,947  
 Pct Good 0.5500  
 Obsol/Observed 0.0000  
 Building Value 116,020

DOCUMENT #	DATE	QS	SALE PRICE
367738	1013	U	70,000
361491	1212	U	
	0794	U	45,000
PERMIT NO	TYPE	DATE	AMOUNT

Appraiser JB J. Brown  
 Appr Date 08/09/22  
 Use Code 0040 Imp Res  
 NBHD 1900.30 FLD PLN PRIOR/40  
 L100 M100 B144

AREA	FLAT	EFF% E/AREA	ACT% A/AREA	EA/AA	HEATED
LIV	1216	1.00	1216	1.00	1216
CONE	480	1.00	480	1.00	480
OFF	144	1.00	144	1.00	144
# Of Bedrooms	03	1.00	976	1.00	976
Sq.Ft.Gr'd Area	1696				

MISC BLDG CODE	DESC	LENGTH	WIDTH	UNITS	ADJ PRICE	EYB DT PCT	ADJUSTMENT	VALUE
1	1 OFF	8.00	10.00	80.00	14.69	1930 P 60.00	.50	470
2	1 OFF	8.00	8.00	64.00	15.94	1970 P 57.00	.50	440
3	1 SHED	40.00	28.00	1120.00	21.37	1948 20 85.00	1.00	3,590
4	2 SHED16	40.00	28.00	1120.00	23.93	1928 20 85.00	1.00	4,020
5	3 SHED	46.00	20.00	920.00	22.61	1948 20 85.00	1.00	3,120
6	4 SALV	.00	.00	1.00	300.00	00 OD 0.00	1.00	300
LAND LUSE DESC	ZONING	UNITS TP	PRICE	ADJUSTMENT	CODE/FACTOR	ADJUSTMENT	VALUE	
1 CK	County Road Cat. MA1	5.00 R	3000.00	.00	.00	.00 TW 1.00	15,000	

MISC	BLDG CODE	DESC	Site Address:	VALMEYER	ZIEBOLD	IL 62295	RD	ADJ PRICE	EYB DT	PCT	ADJUSTMENT	VALUE
			LENGTH	WIDTH	UNITS							
7	5 CONDR	Concrete Drivewa	46.00	14.00	644.00			1.83	2015 P	17.00	.50	980
8	6 SALV	Salvage Structur	.00	.00	1.00			300.00	00 OD	0.00	1.00	300
9	7 SHED	Frame Shed	16.00	12.00	192.00			26.36	2019 A	1.00	1.00	5,010