

PART SE NE

VALMEYER IL 62295

Site Address: 006644 A RD

BLDG # 1
 Style/Stories 2.0 2 Story
 Quality/Design C C-Average
 Building Use 0100 Single Fami
 Exterior Wall F Frame 2.0
 WALL % 100 100%
 Exterior Wall 1
 WALL 1% 000 N/A
 Crawl Sp. Adj
 Slab Adjustment
 Basement
 Combination F1 Frame/1.0
 Attic Area
 Heat/AC Adj AC Central Air
 Comb Ht/AC Adj AC1 Cent AC Cmb
 Fireplace 03 C-Fireplace
 Extra Fireplace 00 N/A
 Res Fixtures 0013 13 Fixtures
 Garage F Frame Garag
 Integral Garage
 Remodeling Adj 05 Complete Re
 Actual Year Blt 1991
 Effect Year Blt 1991
 Cond/Desir/Util A Res CDU - A
 Township Multpl 06 TOWNSHIP #0
 Funct. Obs. % 000000
 Economic Obs. % 000000
 Observed Cond % 000000
 Obs. Cond. Code
 Combination A
 Comb A Ht/AC
 Unfin Low/Level
 Full Basement F Full Baseme
 # Of Bedrooms 04 Four Bedroo
 Sq.Ft.Grđ Area 1810

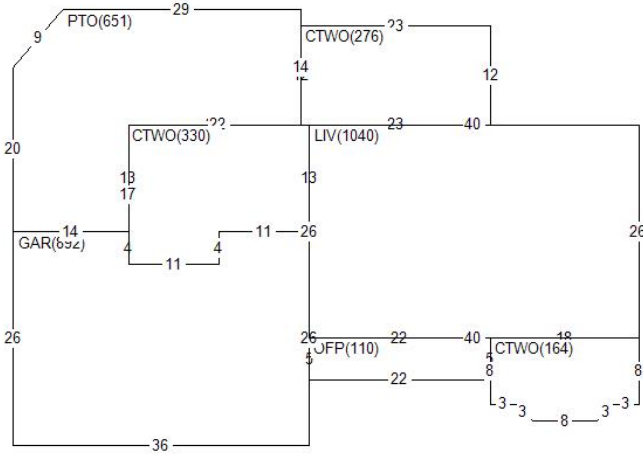

Land Value 7,500
 Misc Value 0
 Bldg Value 192,500
 MOBILEHM VAL 20,250
 TOTAL VALUE 220,250
 Value By Override

RCN 360,789
 Pct Good 0.7800
 Obsol/Observed 0.0000
 Building Value 281,420

DOCUMENT #	DATE	QS	SALE PRICE
320481	1207	U	
	0191	U	

PERMIT NO	TYPE	DATE	AMOUNT
6420	01	1191	

Appraiser KS K. Sondag
 Appr Date 09/22/22
 Use Code 0011 Imp. Farm
 NBHD 1900.10 FLD PLN 60-NEW
 L100 M100 B170

AREA	FLAT	EFF%	E/AREA	ACT%	A/AREA	EA/AA	HEATED
OFFP	110	1.00	110	1.00	110	110	
CTWO	770	1.00	770	1.00	770	770	
GAR	892	1.00	892	1.00	892	892	
PTO	651	1.00	651	1.00	651	651	
LIV	1040	1.00	1040	1.00	1040	1040	1040
CONDR	1224	1.00	1224	1.00	1224	1224	

MISC BLDG CODE	DESC	LENGTH	WIDTH	UNITS	ADJ PRICE	EYB DT PCT	ADJUSTMENT	VALUE
1 1 BRVEN	Brick Veneer	.00	.00	208.00	14.65	1991 A 22.00	1.00	2,380
2 1 OFP	Open Frame Porch	5.00	22.00	110.00	26.28	1991 A 22.00	1.00	2,260
3 1 CONDR	Concrete Drivewa	34.00	36.00	1224.00	3.65	1994 A 19.00	1.00	3,620
4 1 PTO	Concrete Patio	.00	.00	651.00	3.65	1991 A 22.00	1.00	1,850
5 1 GARF	Garage Frame	22.00	18.00	396.00	19.24	1957 A 45.00	1.00	4,190
6 1 F-FRSHEd14	Frame Shed 14'	58.00	24.00	1392.00	21.52	1880 F3 85.00	1.00	4,490
LAND LUSE DESC	ZONING	UNITS	TP	PRICE	ADJUSTMENT	CODE/FACTOR	ADJUSTMENT	VALUE
1 CK	County Road Cat.	2.50	R	3000.00	.00	.00	.00 TW 1.00	7,500

			VALMEYER		IL 62295						
Site Address: 006644			A		RD						
MISC	BLDG CODE	DESC	LENGTH	WIDTH	UNITS	ADJ PRICE	EYB DT	PCT	ADJUSTMENT	VALUE	
7	2 F-LTP	Lean-to Pole	58.00	13.00	754.00	6.80	1940 F3	85.00	1.00	770	
8	2 F-LTCF	Lean-to Conc Flr	58.00	13.00	754.00	3.65	1940 F3	85.00	1.00	410	
9	3 F-LTP	Lean-to Pole	58.00	20.00	1160.00	6.21	1940 F3	85.00	1.00	1,080	
10	3 F-LTCF	Lean-to Conc Flr	58.00	20.00	1160.00	3.65	1940 F3	85.00	1.00	640	
11	4 F-FRSHED12	Frame Shed 12'	40.00	20.00	800.00	24.67	1948 F3	85.00	1.00	2,960	
12	5 F-LTP	Lean-to Pole	40.00	13.00	520.00	7.12	1948 F3	85.00	1.00	560	
13	5 F-LTCF	Lean-to Conc Flr	40.00	13.00	520.00	3.65	1948 F3	85.00	1.00	290	
14	8 F-CONC	Farm Concrete	53.00	30.00	1590.00	2.74	1920 F3	85.00	.75	650	
15	9 F-FRSHED12	Frame Shed 12'	40.00	24.00	960.00	23.66	2007 F3	67.50	1.00	7,380	