

PART LOT 2A SUR 582

WATERLOO IL 62298

Site Address: 007543 OLD BLUFF RD

BLDG # 1  
 Style/Stories 1.0 One Story  
 Quality/Design C C-Average  
 Building Use 0100 Single Fami  
 Exterior Wall F Frame  
 WALL % 100 100%  
 Exterior Wall 1  
 WALL 1% 000 N/A  
 Crawl Sp. Adj C Crawl  
 Slab Adjustment  
 Basement  
 Combination  
 Attic Area  
 Heat/AC Adj AC Central Air  
 Comb Ht/AC Adj  
 Fireplace 03 C-Fireplace  
 Extra Fireplace 00 N/A  
 Res Fixtures 0011 11 Fixtures  
 Garage F Frame Garag  
 Integral Garage  
 Remodeling Adj 04 1/2 - 3/4 U  
 Actual Year Blt 1980  
 Effect Year Blt 1980  
 Cond/Desir/Util A  
 Township Multpl 06 TOWNSHIP #0  
 Funct. Obs. % 000000  
 Economic Obs. % 000000  
 Observed Cond % 000000  
 Obs. Cond. Code  
 Combination A  
 Comb A Ht/AC  
 Unfin Low/Level  
 Full Basement F Full Baseme  
 # Of Bedrooms 04 Four Bedroo  
 Sq.Ft.Grđ Area 1976

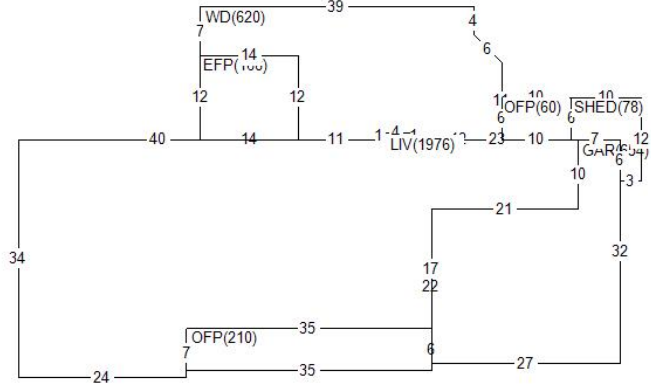

Land Value 9,000  
 Misc Value 34,880  
 Bldg Value 180,480  
 Total Value 224,360  
 Value By CAMA

RCN 269,374  
 Pct Good 0.6700  
 Obsol/Observed 0.0000  
 Building Value 180,480

DOCUMENT # DATE QS SALE PRICE  
 0794 U 75,000

PERMIT NO TYPE DATE AMOUNT

Appraiser JB J. Brown  
 Appr Date 08/18/22  
 Use Code 0040 Imp Res  
 NBHD 1900.10 FLD PLN 60-NEW  
 L100 M100 B170

AREA	FLAT	EFF% E/AREA	ACT% A/AREA	EA/AA HEATED	NBHD
CRWL	5	1.00	5	5	
CONDR	1808	1.00	1808	1808	
EFP	168	1.00	168	168	
WD	620	1.00	620	620	
OFFP	270	1.00	270	270	
GAR	654	1.00	654	654	
LIV	1976	1.00	1976	1976	1976
SHED	78	1.00	78	78	
PTO	290	1.00	290	290	

MISC BLDG CODE	DESC	LENGTH	WIDTH	UNITS	ADJ PRICE	EYB DT PCT	ADJUSTMENT	VALUE
1 1 BRVEN	Brick Veneer	.00	.00	572.00	14.65	1980 A 33.00	1.00	5,620
2 1 OFFP	Open Frame Porch	6.00	35.00	210.00	22.96	1980 A 33.00	1.00	3,230
3 1 EFP	Enclosed Fr. Por	12.00	14.00	168.00	40.88	1980 A 33.00	1.00	4,600
6 1 WD	Wood Deck	.00	.00	620.00	19.35	2003 A 11.00	1.00	10,680
7 1 CONDR	Concrete Drivewa	.00	.00	1808.00	3.65	2007 A 7.00	1.00	6,140
8 1 OFFP	Open Frame Porch	6.00	10.00	60.00	32.50	2007 A 7.00	1.00	1,810
LAND LUSE DESC	ZONING	UNITS TP	PRICE	ADJUSTMENT CODE/FACTOR			VALUE	
1 CK County Road Cat.	MAL	4.00 R	3000.00	TW	1.00 CN	.75 .00	.00	9,000

MISC BLDG CODE	DESC	Site Address:	WATERLOO	OLD BLUFF	IL 62298	RD	ADJ PRICE	EYB DT	PCT	ADJUSTMENT	VALUE
		LENGTH	WIDTH	UNITS							
9 1 SHED	Frame Shed	.00	.00	78.00			26.75	2007 A	7.00	1.00	1,940
10 1 PTO	Concrete Patio	.00	.00	290.00			2.99	2019 A	1.00	.82	860