

PART TAX LOT 4 & PART SUR 424 &
PART TAX LOT 1 SEC 36

VALMEYER IL 62295
Site Address: 000457 HAWK POINTE

BLDG # 1
 Style/Stories 2.0 2 Story
 Quality/Design C C-Average
 Building Use 0100 Single Fami
 Exterior Wall F Frame 2.0
 WALL % 100 100%
 Exterior Wall 1
 WALL 1% 000 N/A
 Crawl Sp. Adj
 Slab Adjustment
 Basement
 Combination
 Attic Area FA Finished
 Heat/AC Adj AC Central Air
 Comb Ht/AC Adj
 Fireplace 24 C-2 Fr.Ones
 Extra Fireplace 00 N/A
 Res Fixtures 0018 18 Fixtures
 Garage F Frame Garag
 Integral Garage
 Remodeling Adj 01 No Remodeli
 Actual Year Blt 2004
 Effect Year Blt 2004
 Cond/Desir/Util A
 Township Multpl 06
 Funct. Obs. %
 Economic Obs. %
 Observed Cond %
 Obs. Cond. Code
 Combination A
 Comb A Ht/AC
 Unfin Low/Level
 Full Basement F Full Baseme
 # Of Bedrooms 04 Four Bedroo
 Sq.Ft.Grđ Area 1205

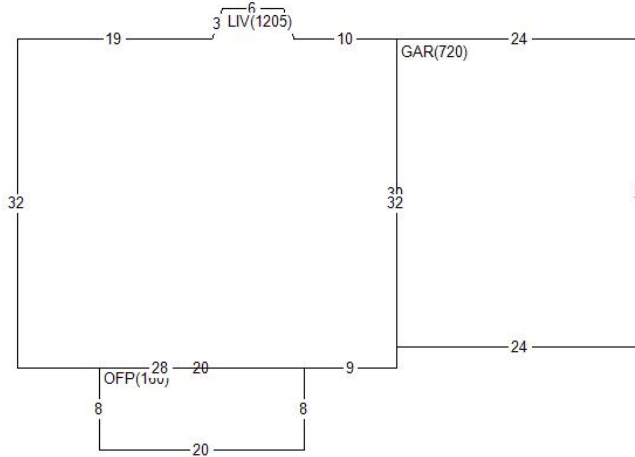

Land Value 96,570
 Misc Value 11,080
 Bldg Value 179,480
 Total Value 287,130
 Value By CAMA

RCN 199,417
 Pct Good 0.9000
 Obsol/Observed 0.0000
 Building Value 179,480

DOCUMENT #	DATE	QS	SALE PRICE
398889	1118	U	
286307	0404	U	15,100

PERMIT NO	TYPE	DATE	AMOUNT
11158	00	0904	
11158	01	0104	

Appraiser JB J. Brown
 Appr Date 08/19/22
 Use Code 0040 Imp Res
 NBHD 62000.20 VLMYR 2.0 STORY
 L100 M100 B100

AREA	FLAT	EFF%	E/AREA	ACT%	A/AREA	EA/AA	HEATED
LIV	1205	1.00	1205	1.00	1205	1205	1205
OFFP	160	1.00	160	1.00	160	160	
IG	720	1.00	720	1.00	720	720	
GAR	720	1.00	720	1.00	720	720	
CONDR	1644	1.00	1644	1.00	1644	1644	
FA	288	1.00	288	1.00	288	288	

MISC BLDG CODE	DESC	LENGTH	WIDTH	UNITS	ADJ PRICE	EYB DT	PCT	ADJUSTMENT	VALUE
1 1 OFFP2	Open Fr Porch 2	8.00	20.00	160.00	35.66	2004 A	10.00	1.00	5,140
2 1 CONDR	Concrete Drivewa	.00	.00	1644.00	3.65	2004 A	10.00	1.00	5,400
3 1 PTO	Concrete Patio	15.00	15.00	225.00	2.99	2011 P	20.00	.82	540

LAND LUSE DESC	ZONING	UNITS TP	PRICE	ADJUSTMENT	CODE/FACTOR	VALUE
1 CJ County Road Cat.	MA1	10.07 R	9589.59	TW 1.00	.00 .00	96,570