

LOT 362 NEW VALMEYER PHASE 6

VALMEYER IL 62295
Site Address: 000235 W WOODLAND RIDGE

BLDG # 1
 Style/Stories 1.0 One Story
 Quality/Design C C-Average
 Building Use 0100 Single Fami
 Exterior Wall F Frame
 WALL % 100 100%
 Exterior Wall 1
 WALL 1% 000 N/A
 Crawl Sp. Adj
 Slab Adjustment
 Basement
 Combination
 Attic Area
 Heat/AC Adj AC Central Air
 Comb Ht/AC Adj
 Fireplace 00 N/A
 Extra Fireplace 00 N/A
 Res Fixtures 0009 09 Fixtures
 Garage F Frame Garag
 Integral Garage
 Remodeling Adj 01 No Remodeli
 Actual Year Blt 2005
 Effect Year Blt 2005
 Cond/Desir/Util A
 Township Multpl 06 Res CDU - A
 Funct. Obs. % TOWNSHIP #0
 Economic Obs. %
 Observed Cond %
 Obs. Cond. Code
 Combination A
 Comb A Ht/AC
 Unfin Low/Level
 Full Basement F Full Baseme
 # Of Bedrooms 03 Three Bedro
 Sq.Ft.Grnd Area 1782

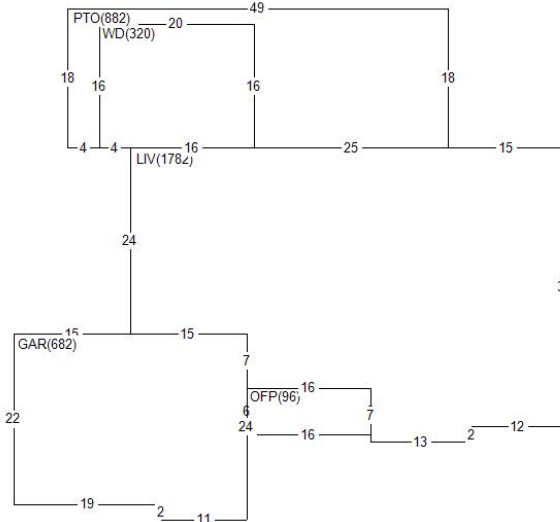

Land Value 26,760
 Misc Value 17,390
 Bldg Value 183,690
 Total Value 227,840
 Value By CAMA

RCN 201,853
 Pct Good 0.9100
 Obsol/Observed 0.0000
 Building Value 183,690

DOCUMENT #	DATE	QS	SALE PRICE
354975	0412	Q	175,000
297616	0605	Q	189,029

PERMIT NO	TYPE	DATE	AMOUNT
R1-05-08	01	0205	

Appraiser KS K. Sondag
 Appr Date 07/05/22
 Use Code 0040 Imp Res
 NBHD 62000.10 VLMYR 1.0 STORY
 L100 M100 B144

AREA	FLAT	EFF%	E/AREA	ACT%	A/AREA	EA/AA	HEATED
CONDR	1238	1.00	1238	1.00	1238	1238	
OFFP	96	1.00	96	1.00	96	96	
GAR	682	1.00	682	1.00	682	682	
WD	320	1.00	320	1.00	320	320	
LIV	1782	1.00	1782	1.00	1782	1782	1782
PTO	882	1.00	882	1.00	882	882	

MISC BLDG CODE	DESC	LENGTH	WIDTH	UNITS	ADJ PRICE	EYB DT PCT	ADJUSTMENT	VALUE
1	1 OFFP	6.00	16.00	96.00	27.48	2005 A 9.00	1.00	2,400
2	1 WD	16.00	20.00	320.00	19.35	2005 A 9.00	1.00	5,640
3	1 PTO	18.00	49.00	882.00	3.65	2015 A 2.00	1.00	3,160
4	1 CONDR	.00	.00	1238.00	3.65	2019 A 1.00	1.00	4,470
5	1 BRVEN	.00	.00	129.00	14.65	2005 A 9.00	1.00	1,720

LAND LUSE DESC	ZONING	UNITS TP	PRICE	ADJUSTMENT	CODE/FACTOR	VALUE
1 6200 VALMEYER	VR1	1.00 ST	26760.00	TW 1.00	.00 .00	26,760