

LOT 367 NEW VALMEYER PHASE 6

VALMEYER IL 62295

Site Address: 000313 W WOODLAND RIDGE

BLDG # 1  
 Style/Stories 2.0 2 Story  
 Quality/Design C C-Average  
 Building Use 0100 Single Fami  
 Exterior Wall F Frame 2.0  
 WALL % 100 100%  
 Exterior Wall 1  
 WALL 1% 000 N/A  
 Crawl Sp. Adj C Crawl  
 Slab Adjustment  
 Basement  
 Combination  
 Attic Area  
 Heat/AC Adj AC Central Air  
 Comb Ht/AC Adj  
 Fireplace 31 DirectVent  
 Extra Fireplace 00 N/A  
 Res Fixtures 0011 11 Fixtures  
 Garage F Frame Garag  
 Integral Garage  
 Remodeling Adj 01 No Remodeli  
 Actual Year Blt 2002  
 Effect Year Blt 2002  
 Cond/Desir/Util A Res CDU - A  
 Township Multpl 06 TOWNSHIP #0  
 Funct. Obs. %  
 Economic Obs. %  
 Observed Cond %  
 Obs. Cond. Code  
 Combination A  
 Comb A Ht/AC  
 Unfin Low/Level  
 Full Basement F Full Baseme  
 # Of Bedrooms 03 Three Bedro  
 Sq.Ft.Grd Area 1032

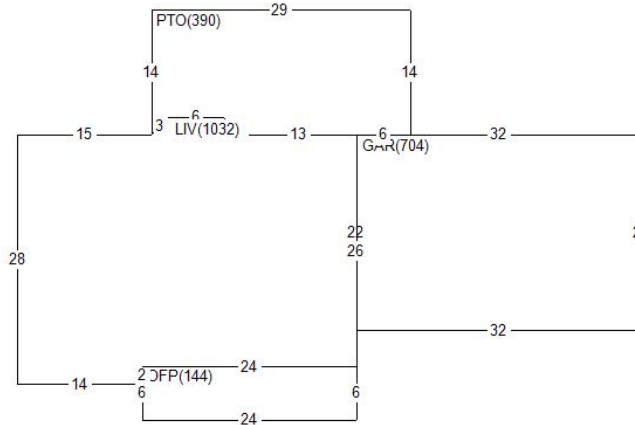

Land Value 26,760  
 Misc Value 12,320  
 Bldg Value 134,850  
 Total Value 173,930  
 Value By CAMA

RCN 153,236  
 Pct Good 0.8800  
 Obsol/Observed 0.0000  
 Building Value 134,850

DOCUMENT #	DATE	QS	SALE PRICE
336353	1109	Q	184,000
297376	0505	Q	195,000
	0302	Q	29,500

PERMIT NO	TYPE	DATE	AMOUNT
R1-02-05	00	0602	
R1-02-05	01	0202	

Appraiser KS K. Sondag  
 Appr Date 07/05/22  
 Use Code 0040 Imp Res  
 NBHD 62000.20 VLMYR 2.0 STORY  
 L100 M100 B100

AREA	FLAT	EFF% E/AREA	ACT% A/AREA	EA/AA HEATED
CONDR	2418	1.00	2418	1.00 2418 2418
CRWL	16	1.00	16	1.00 16 16
OFP	144	1.00	144	1.00 144 144
GAR	704	1.00	704	1.00 704 704
PTO	390	1.00	390	1.00 390 390
LIV	1032	1.00	1032	1.00 1032 1032 1032

MISC BLDG CODE	DESC	LENGTH	WIDTH	UNITS	ADJ PRICE	EYB DT PCT	ADJUSTMENT	VALUE
1 1 OFP	Open Frame Porch	6.00	24.00	144.00	24.29	2002 A 12.00	1.00	3,080
2 1 PTO	Concrete Patio	.00	.00	390.00	3.65	2002 A 12.00	1.00	1,250
3 1 CONDR	Concrete Drivewa	48.00	29.00	1392.00	3.65	2002 A 12.00	1.00	4,470
4 1 CONDR	Concrete Drivewa	.00	.00	1026.00	3.65	2009 A 6.00	1.00	3,520

LAND LUSE DESC	ZONING	UNITS TP	PRICE	ADJUSTMENT	CODE/FACTOR	VALUE
1 6200 VALMEYER	VR1	1.00 ST	26760.00	TW 1.00	.00 .00	26,760