

LOT 363 NEW VALMEYER PHASE 6

VALMEYER IL 62295

Site Address: 000239 W WOODLAND RIDGE

BLDG # 1
 Style/Stories 1.5 1 1/2 Story
 Quality/Design C C-Average
 Building Use 0100 Single Fami
 Exterior Wall F Frame 1.5
 WALL % 100 100%
 Exterior Wall 1
 WALL 1% 000 N/A
 Crawl Sp. Adj
 Slab Adjustment
 Basement
 Combination F2 Frame/2.0
 Attic Area
 Heat/AC Adj AC Central Air
 Comb Ht/AC Adj AC2 Cent AC Cmb
 Fireplace 31 DirectVent
 Extra Fireplace 00 N/A
 Res Fixtures 0011 11 Fixtures
 Garage F Frame Garag
 Integral Garage
 Remodeling Adj 01 No Remodeli
 Actual Year Blt 2006
 Effect Year Blt 2006
 Cond/Desir/Util A Res CDU - A
 Township Multpl 06 TOWNSHIP #0
 Funct. Obs. % 000000
 Economic Obs. % 000000
 Observed Cond % 000000
 Obs. Cond. Code
 Combination A
 Comb A Ht/AC
 Unfin Low/Level
 Full Basement F Full Baseme
 # Of Bedrooms 04 Four Bedroo
 Sq.Ft.Grđ Area 1128

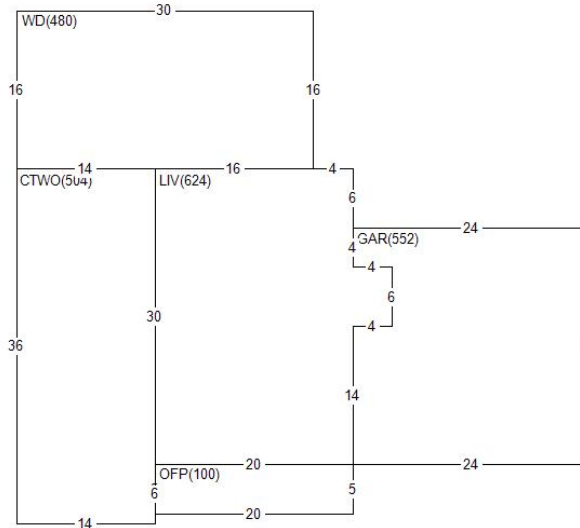

Land Value 26,760
 Misc Value 20,920
 Bldg Value 149,200
 Total Value 196,880
 Value By CAMA

RCN 162,178
 Pct Good 0.9200
 Obsol/Observed 0.0000
 Building Value 149,200

DOCUMENT #	DATE	QS	SALE PRICE
427276	1222	U	
364710	0513	U	124,000
361489	1212	U	208,630
PERMIT NO	TYPE	DATE	AMOUNT
R1-18-07	04	0707	
R1-05-31	01	1105	

Appraiser AS A. Schwar
 Apr Date 01/05/23
 Use Code 0040 Imp Res
 NBHD 62000.15 VLMYR 1.5 STORY
 L100 M100 B100

AREA	FLAT	EFF% E/AREA	ACT% A/AREA	EA/AA HEATED
CONDR	684	1.00	684	684
PTO	180	1.00	180	180
GAR	552	1.00	552	552
OFFP	100	1.00	100	100
CTWO	504	1.00	504	504
LIV	624	1.00	624	624
WD	480	1.00	480	480

MISC BLDG CODE	DESC	LENGTH	WIDTH	UNITS	ADJ PRICE	EYB DT PCT	ADJUSTMENT	VALUE
1 1 PTO	Concrete Patio	12.00	15.00	180.00	3.65	2006 A 8.00	1.00	600
2 1 OFFP	Open Frame Porch	5.00	20.00	100.00	27.00	2006 A 8.00	1.00	2,480
3 1 CONDR	Concrete Drivewa	18.00	38.00	684.00	3.65	2006 A 8.00	1.00	2,300
4 1 BRVEN	Brick Veneer	.00	.00	512.00	14.65	2006 A 8.00	1.00	6,900
5 1 WD	Wood Deck	30.00	16.00	480.00	19.35	2008 A 7.00	1.00	8,640

LAND LUSE DESC	ZONING	UNITS TP	PRICE	ADJUSTMENT	CODE/FACTOR	VALUE
1 6200 VALMEYER	VR1	1.00 ST	26760.00	TW 1.00	.00 .00 .00	26,760