

LOT 372 NEW VALMEYER PHASE 6

VALMEYER IL 62298
Site Address: 000333 W WOODLAND RIDGE

BLDG # 1
 Style/Stories 1.0 One Story
 Quality/Design C C-Average
 Building Use 0100 Single Fami
 Exterior Wall F Frame
 WALL % 080 080%
 Exterior Wall 1 M Masonry
 WALL 1% 020 020%
 Crawl Sp. Adj C Crawl
 Slab Adjustment
 Basement RC C-Rec Room
 Combination
 Attic Area
 Heat/AC Adj AC Central Air
 Comb Ht/AC Adj
 Fireplace 23 C-2 Fr.Pl/2
 Extra Fireplace 00 N/A
 Res Fixtures 0012 12 Fixtures
 Garage M Masonry Gar
 Integral Garage
 Remodeling Adj 01 No Remodeli
 Actual Year Blt 2003
 Effect Year Blt 2003
 Cond/Desir/Util A Res CDU - A
 Township Multpl 06 TOWNSHIP #0
 Funct. Obs. %
 Economic Obs. %
 Observed Cond %
 Obs. Cond. Code
 Combination A
 Comb A Ht/AC
 Unfin Low/Level
 Full Basement F Full Baseme
 # Of Bedrooms 04 Four Bedroo
 Sq.Ft.Grđ Area 2254

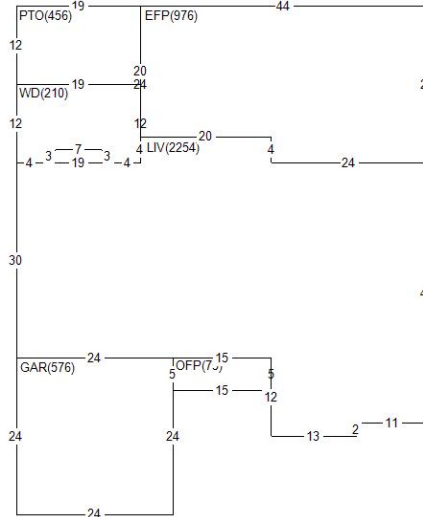

Land Value 26,760
 Misc Value 65,520
 Bldg Value 252,790
 Total Value 345,070
 Value By CAMA

RCN 284,028
 Pct Good 0.8900
 Obsol/Observed 0.0000
 Building Value 252,790

DOCUMENT #	DATE	QS	SALE PRICE
427302	1222	Q	435,000
388684	0317	Q	315,000
371257	0514	Q	310,000

PERMIT NO	TYPE	DATE	AMOUNT
R1-05-09	08	0305	
R1-03-54	01	1103	

Appraiser AS A. Schwar
 Appr Date 01/06/23
 Use Code 0040 Imp Res
 NBHD 62000.10 VLMYR 1.0 STORY
 L100 M100 B144

AREA	FLAT	EFF%	E/AREA	ACT%	A/AREA	EA/AA	HEATED
CONDR	816	1.00	816	1.00	816	816	
POOL	200	1.00	200	1.00	200	200	
BSMR	2000	1.00	2000	1.00	2000	2000	
CRWL	18	1.00	18	1.00	18	18	
GAR	576	1.00	576	1.00	576	576	
OFF	75	1.00	75	1.00	75	75	
PTO	456	1.00	456	1.00	456	456	
WD	210	1.00	210	1.00	210	210	
LIV	2254	1.00	2254	1.00	2254	2254	2254
EFP	976	1.00	976	1.00	976	976	

MISC BLDG CODE	DESC	LENGTH	WIDTH	UNITS	ADJ PRICE	EYB DT	PCT	ADJUSTMENT	VALUE
1 1 POOLVNL	Vinyl Ln Res Poo	.00	.00	200.00	41.00	2003 A	11.00	1.00	7,300
2 1 OFF	Open Frame Porch	15.00	5.00	75.00	30.16	2003 A	11.00	1.00	2,010
3 1 WD	Wood Deck	.00	.00	210.00	19.35	2003 A	11.00	1.00	3,620
4 1 PTO	Concrete Patio	19.00	24.00	456.00	3.65	2003 F	18.00	1.00	1,360
5 1 CONDR	Concrete Drivewa	34.00	24.00	816.00	3.65	2003 P	26.00	1.00	2,200
6 1 EFP2	Encl Fr Porch 2	.00	.00	976.00	52.18	2003 A	11.00	1.00	45,330

LAND LUSE DESC	ZONING	UNITS TP	PRICE	ADJUSTMENT	CODE/FACTOR	VALUE
1 6200 VALMEYER	VR1	1.00 ST	26760.00	TW	1.00	26,760

Req By: KRIS_K
AARON SIMS
333 W WOODLAND RIDGE

MISC BLDG CODE	DESC	Site Address:	VALMEYER	WOODLAND RIDGE	IL 62298	ADJ PRICE	EYB DT	PCT	ADJUSTMENT	VALUE
		LENGTH	WIDTH	UNITS						
8 1 DORM	Dormer	000333 W	.00	.00	2.00	1850.00	2003 OD	0.00	1.00	3,700