

LOT 387 NEW VALMEYER PHASE 6

VALMEYER IL 62295

Site Address: 000111 PEREGRINE LN

BLDG # 1  
 Style/Stories 1.0 One Story  
 Quality/Design C C-Average  
 Building Use 0100 Single Fami  
 Exterior Wall F Frame  
 WALL % 100 100%  
 Exterior Wall 1  
 WALL 1% 000 N/A  
 Crawl Sp. Adj C Crawl  
 Slab Adjustment  
 Basement RC C-Rec Room  
 Combination  
 Attic Area  
 Heat/AC Adj AC Central Air  
 Comb Ht/AC Adj  
 Fireplace 31 DirectVent  
 Extra Fireplace 00 N/A  
 Res Fixtures 0013 13 Fixtures  
 Garage F Frame Garag  
 Integral Garage  
 Remodeling Adj 01 No Remodeli  
 Actual Year Blt 2001  
 Effect Year Blt 2001  
 Cond/Desir/Util A Res CDU - A  
 Township Multpl 06 TOWNSHIP #0  
 Funct. Obs. %  
 Economic Obs. %  
 Observed Cond %  
 Obs. Cond. Code  
 Combination A  
 Comb A Ht/AC  
 Unfin Low/Level  
 Full Basement  
 # Of Bedrooms 03 Three Bedro  
 Sq.Ft.Grđ Area 1804

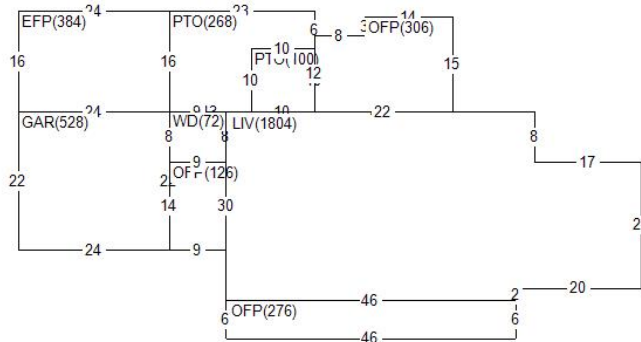

Land Value 26,760  
 Misc Value 36,260  
 Bldg Value 188,070  
 Total Value 251,090  
 Value By CAMA

RCN 213,720  
 Pct Good 0.8800  
 Obsol/Observed 0.0000  
 Building Value 188,070

DOCUMENT #	DATE	QS	SALE PRICE
293305	1204	Q	184,500
	0399	Q	24,000

PERMIT NO	TYPE	DATE	AMOUNT
BP-11-01	10	0611	
BP-10-06	07	0610	
R1-05-35	07	1205	

Appraiser KS K. Sondag  
 Appr Date 07/06/22  
 Use Code 0040 Imp Res  
 NBHD 62000.10 VLMYR 1.0 STORY  
 L100 M100 B144

AREA	FLAT	EFF% E/AREA	ACT% A/AREA	EA/AA	HEATED
CRWL	424	1.00	424	1.00	424
CONDR	1448	1.00	1448	1.00	1448
BSMR	478	1.00	478	1.00	478
OFP	708	1.00	708	1.00	708
PTO	652	1.00	652	1.00	652
EFF	384	1.00	384	1.00	384
GAR	528	1.00	528	1.00	528
WD	72	1.00	72	1.00	72
LIV	1804	1.00	1804	1.00	1804

MISC BLDG CODE	DESC	LENGTH	WIDTH	UNITS	ADJ PRICE	EYB DT PCT	ADJUSTMENT	VALUE
1 1 OFP	Open Frame Porch	6.00	46.00	276.00	23.30	2002 A 12.00	1.00	5,660
2 1 OFP	Open Frame Porch	9.00	14.00	126.00	25.15	2002 A 12.00	1.00	2,790
3 1 WD	Wood Deck	9.00	8.00	72.00	19.35	2002 A 12.00	1.00	1,230
4 1 PTO	Concrete Patio	10.00	10.00	100.00	3.65	2002 A 12.00	1.00	320
5 1 EFF	Enclosed Fr. Por	16.00	24.00	384.00	36.75	2005 A 9.00	1.00	12,840
6 1 PTO	Concrete Patio	.00	.00	268.00	3.65	2005 A 9.00	1.00	890

LAND LUSE DESC	ZONING	UNITS TP	PRICE	ADJUSTMENT	CODE/FACTOR	VALUE
1 6200 VALMEYER	VR1	1.00 ST	26760.00	TW	1.00 .00 .00	26,760

Req By: KRIS\_K  
 RENNIE S & JOHN T RODGERS  
 111 PEREGRINE LN

MISC BLDG CODE		DESC	Site Address:	VALMEYER	PEREGRINE	IL 62295	LN	EYB DT	PCT	ADJUSTMENT	VALUE
			000111								
			LENGTH	WIDTH	UNITS	ADJ PRICE					
7	1 CONDR	Concrete Drivewa	.00	.00	1448.00	3.65	2005	A	9.00	1.00	4,810
8	1 OFP	Open Frame Porch	.00	.00	306.00	22.77	2012	A	4.00	1.00	6,690
9	1 PTO	Concrete Patio	.00	.00	284.00	3.65	2019	A	1.00	1.00	1,030