

Req By: KRIS_K
 ADAM L TYBERENDT &
 STEFANIE JOHNSON-TYBERENDT
 324 W WOODLAND RIDGE

LOT 383 NEW VALMEYER PHASE 6

VALMEYER IL 62295

Site Address: 000324 W WOODLAND RIDGE

BLDG # 1
 Style/Stories 1.0 One Story
 Quality/Design C C-Average
 Building Use 0100 Single Fami
 Exterior Wall F Frame
 WALL % 100 100%
 Exterior Wall 1
 WALL 1% 000 N/A
 Crawl Sp. Adj C Crawl
 Slab Adjustment S Slab
 Basement RC C-Rec Room
 Combination
 Attic Area
 Heat/AC Adj AC Central Air
 Comb Ht/AC Adj
 Fireplace 03 C-Fireplace
 Extra Fireplace 00 N/A
 Res Fixtures 0015 15 Fixtures
 Garage F Frame Garag
 Integral Garage
 Remodeling Adj 01 No Remodeli
 Actual Year Blt 2004
 Effect Year Blt 2004
 Cond/Desir/Util A Res CDU - A
 Township Multpl 06 TOWNSHIP #0
 Funct. Obs. %
 Economic Obs. %
 Observed Cond %
 Obs. Cond. Code
 Combination A
 Comb A Ht/AC
 Unfin Low/Level
 Full Basement F Full Baseme
 # Of Bedrooms 04 Four Bedroo
 Sq.Ft.Grđ Area 2246

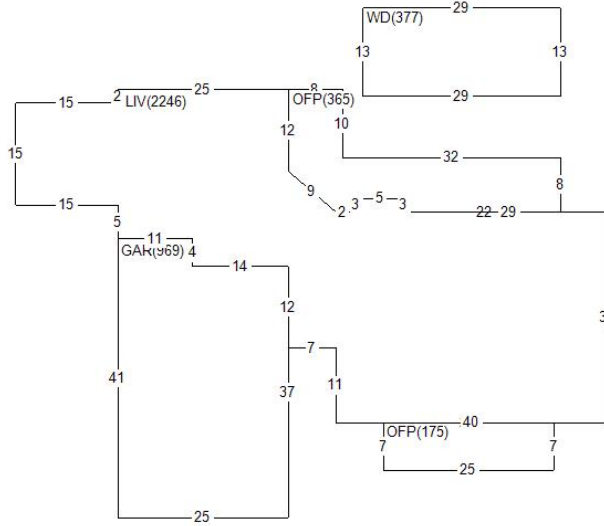

Land Value 26,760
 Misc Value 27,110
 Bldg Value 241,380
 Total Value 295,250
 Value By CAMA

RCN 268,199
 Pct Good 0.9000
 Obsol/Observed 0.0000
 Building Value 241,380

DOCUMENT #	DATE	QS	SALE PRICE
413043	1220	U	270,000
378556	0715	U	
358965	0912	Q	225,000
PERMIT NO	TYPE	DATE	AMOUNT
R1-13-01	09	0113	
R1-04-24	01	0504	

Appraiser KS K. Sondag
 Appr Date 07/05/22
 Use Code 0040 Imp Res
 NBHD 62000.10 VLMYR 1.0 STORY
 L100 M100 B144

AREA	FLAT	EFF% E/AREA	ACT% A/AREA	EA/AA	HEATED
CONDR	1612	1.00	1612	1.00	1612
CRWL	14	1.00	14	1.00	14
BSMR	396	1.00	396	1.00	396
OFF	540	1.00	540	1.00	540
GAR	969	1.00	969	1.00	969
LIV	2246	1.00	2246	1.00	2246
SLAB	225	1.00	225	1.00	225
WD	377	1.00	377	1.00	377

MISC BLDG CODE	DESC	LENGTH	WIDTH	UNITS	ADJ PRICE	EYB DT PCT	ADJUSTMENT	VALUE
1 1 OFF	Open Frame Porch	7.00	25.00	175.00	23.43	2004 A 10.00	1.00	3,690
2 1 OFF	Open Frame Porch	.00	.00	365.00	22.13	2004 A 10.00	1.00	7,270
3 1 CONDR	Concrete Drivewa	.00	.00	1612.00	3.65	2004 A 10.00	1.00	5,300
4 1 DORM	Dormer	.00	.00	2.00	1850.00	2004 OD 0.00	1.00	3,700
5 1 WD	Wood Deck	29.00	13.00	377.00	19.35	2015 A 2.00	1.00	7,150

LAND LUSE DESC	ZONING	UNITS TP	PRICE	ADJUSTMENT	CODE/FACTOR	VALUE
1 6200 VALMEYER	VR1	1.00 ST	26760.00	TW 1.00	.00 .00 .00	26,760