

Req By: KRIS_K
 ROBERT A LEELING
 MARY J GEOLAT
 110 PEREGRINE LN

LOT 389 NEW VALMEYER PHASE 6

VALMEYER IL 62295

Site Address: 000110 PEREGRINE LN

BLDG # 1
 Style/Stories 1.0 One Story
 Quality/Design C C-Average
 Building Use 0100 Single Fami
 Exterior Wall F Frame
 WALL % 100 100%
 Exterior Wall 1
 WALL 1% 000 N/A
 Crawl Sp. Adj
 Slab Adjustment
 Basement RC C-Rec Room
 Combination
 Attic Area
 Heat/AC Adj AC Central Air
 Comb Ht/AC Adj
 Fireplace 00 N/A
 Extra Fireplace 00 N/A
 Res Fixtures 0009 09 Fixtures
 Garage F Frame Garag
 Integral Garage
 Remodeling Adj 01 No Remodeli
 Actual Year Blt 2005
 Effect Year Blt 2005
 Cond/Desir/Util A Res CDU - A
 Township Multpl 06 TOWNSHIP #0
 Funct. Obs. %
 Economic Obs. %
 Observed Cond %
 Obs. Cond. Code
 Combination A
 Comb A Ht/AC
 Unfin Low/Level
 Full Basement F Full Baseme
 # Of Bedrooms 03 Three Bedro
 Sq.Ft.Grd Area 1782

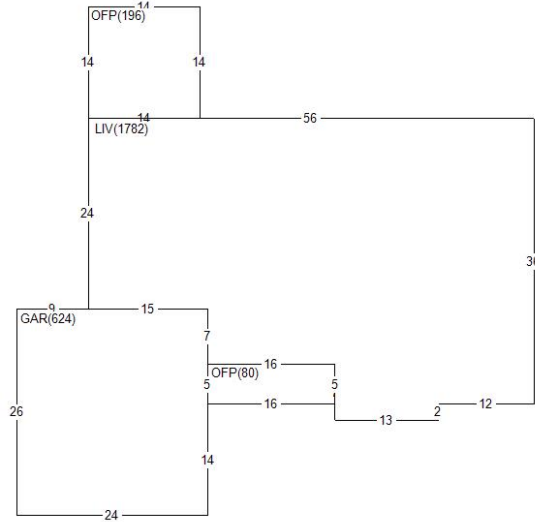

Land Value 26,760
 Misc Value 16,400
 Bldg Value 189,740
 Total Value 232,900
 Value By CAMA

RCN 208,508
 Pct Good 0.9100
 Obsol/Observed 0.0000
 Building Value 189,740

DOCUMENT #	DATE	QS	SALE PRICE
361806	0113	Q	155,000
285585	0304	Q	31,444

PERMIT NO	TYPE	DATE	AMOUNT
R1-06-01	04	0206	
R1-05-10	01	0405	

Appraiser KS K. Sondag
 Appr Date 07/06/22
 Use Code 0040 Imp Res
 NBHD 62000.10 VLMYR 1.0 STORY
 L100 M100 B144

AREA	FLAT	EFF%	E/AREA	ACT%	A/AREA	EA/AA	HEATED
CONDR	972	1.00	972	1.00	972	972	
BSMR	896	1.00	896	1.00	896	896	
OFF	276	1.00	276	1.00	276	276	
LIV	1782	1.00	1782	1.00	1782	1782	1782
GAR	624	1.00	624	1.00	624	624	
PTO	545	1.00	545	1.00	545	545	

MISC BLDG CODE	DESC	LENGTH	WIDTH	UNITS	ADJ PRICE	EYB DT	PCT	ADJUSTMENT	VALUE
1 1 OFF	Open Frame Porch	5.00	16.00	80.00	29.38	2005 A	9.00	1.00	2,140
2 1 CONDR	Concrete Drivewa	.00	.00	972.00	3.65	2005 F	16.00	1.00	2,980
3 1 OFF	Open Frame Porch	14.00	14.00	196.00	22.86	2015 A	2.00	1.00	4,390
4 1 PTO	Concrete Patio	.00	.00	545.00	3.65	2013 A	3.00	1.00	1,930
5 1 SHED	Frame Shed	12.00	16.00	192.00	26.36	2015 A	2.00	1.00	4,960

LAND LUSE DESC	ZONING	UNITS TP	PRICE	ADJUSTMENT	CODE/FACTOR	VALUE
1 6200 VALMEYER	VR1	1.00 ST	26760.00	TW 1.00	.00 .00 .00	26,760