

LOT 210 NEW VALMEYER PHASE 4

VALMEYER IL 62295

Site Address: 000227 N MEYER AV

BLDG # 1
 Style/Stories 1.0 One Story
 Quality/Design C C-Average
 Building Use 0100 Single Fami
 Exterior Wall F Frame
 WALL % 100 100%
 Exterior Wall 1
 WALL 1% 000 N/A
 Crawl Sp. Adj C Crawl
 Slab Adjustment
 Basement
 Combination
 Attic Area
 Heat/AC Adj AC Central Air
 Comb Ht/AC Adj
 Fireplace 31 DirectVent
 Extra Fireplace 00 N/A
 Res Fixtures 0008 08 Fixtures
 Garage F Frame Garag
 Integral Garage
 Remodeling Adj 01 No Remodeli
 Actual Year Blt 1997
 Effect Year Blt 1997
 Cond/Desir/Util A Res CDU - A
 Township Multpl 06 TOWNSHIP #0
 Funct. Obs. % 000000
 Economic Obs. % 000000
 Observed Cond % 000000
 Obs. Cond. Code
 Combination A
 Comb A Ht/AC
 Unfin Low/Level
 Full Basement F Full Baseme
 # Of Bedrooms 03 Three Bedro
 Sq.Ft.Grđ Area 1701

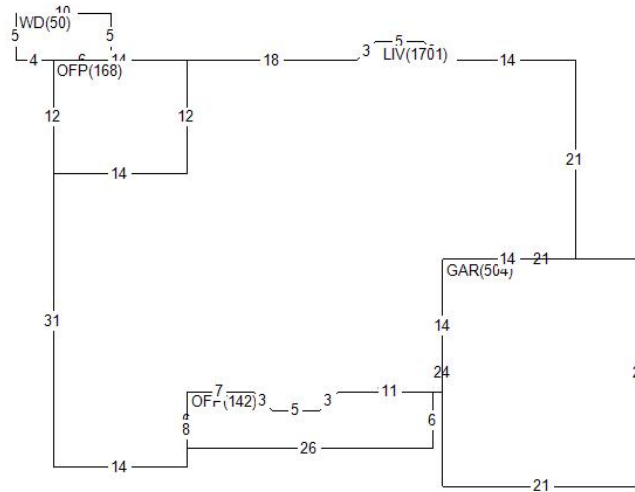

Land Value 26,760
 Misc Value 14,190
 Bldg Value 162,300
 Total Value 203,250
 Value By CAMA

RCN 193,209
 Pct Good 0.8400
 Obsol/Observed 0.0000
 Building Value 162,300

DOCUMENT #	DATE	QS	SALE PRICE
419167	0821	Q	195,000
	0896	Q	20,000
	1194	U	7,500

PERMIT NO	TYPE	DATE	AMOUNT
R1-97-10	00	0298	
	01	0897	

Appraiser KS K. Sondag
 Appr Date 07/06/22
 Use Code 0040 Imp Res
 NBHD 62000.10 VLMYR 1.0 STORY
 L100 M100 B144

AREA	FLAT	EFF% E/AREA	ACT% A/AREA	EA/AA HEATED
CRWL	28	1.00	28	28
CONDR	1108	1.00	1108	1108
OFFP	310	1.00	310	310
GAR	504	1.00	504	504
WD	50	1.00	50	50
LIV	1701	1.00	1701	1701

MISC BLDG CODE	DESC	LENGTH	WIDTH	UNITS	ADJ PRICE	EYB DT PCT	ADJUSTMENT	VALUE
1 1 OFFP	Open Frame Porch	.00	.00	142.00	24.38	1997 A 16.00	1.00	2,910
2 1 OFFP	Open Frame Porch	12.00	14.00	168.00	23.59	1997 A 16.00	1.00	3,330
3 1 CONDR	Concrete Drivewa	.00	.00	1108.00	3.65	1997 A 16.00	1.00	3,400
4 1 DORM	Dormer	.00	.00	2.00	1850.00	1997 OD 0.00	1.00	3,700
5 1 WD	Wood Deck	5.00	10.00	50.00	19.35	2001 A 12.00	1.00	850

LAND LUSE DESC	ZONING	UNITS TP	PRICE	ADJUSTMENT	CODE/FACTOR	VALUE
1 6200 VALMEYER	VR1	1.00 ST	26760.00	.00	.00 TW 1.00	26,760