

LOT 212 NEW VALMEYER PHASE 4

VALMEYER IL 62295

Site Address: 000235 N MEYER AV

BLDG # 1
 Style/Stories 1.0 One Story
 Quality/Design C C-Average
 Building Use 0100 Single Fami
 Exterior Wall F Frame
 WALL % 100 100%
 Exterior Wall 1
 WALL 1% 000 N/A
 Crawl Sp. Adj
 Slab Adjustment
 Basement RC C-Rec Room
 Combination
 Attic Area
 Heat/AC Adj AC Central Air
 Comb Ht/AC Adj
 Fireplace 03 C-Fireplace
 Extra Fireplace 00 N/A
 Res Fixtures 0011 11 Fixtures
 Garage F Frame Garag
 Integral Garage
 Remodeling Adj 01 No Remodeli
 Actual Year Blt 1995
 Effect Year Blt 1995
 Cond/Desir/Util A Res CDU - A
 Township Multpl 06 TOWNSHIP #0
 Funct. Obs. % 000000
 Economic Obs. % 000000
 Observed Cond % 000000
 Obs. Cond. Code
 Combination A
 Comb A Ht/AC
 Unfin Low/Level
 Full Basement F Full Baseme
 # Of Bedrooms 03 Three Bedro
 Sq.Ft.Grnd Area 1686

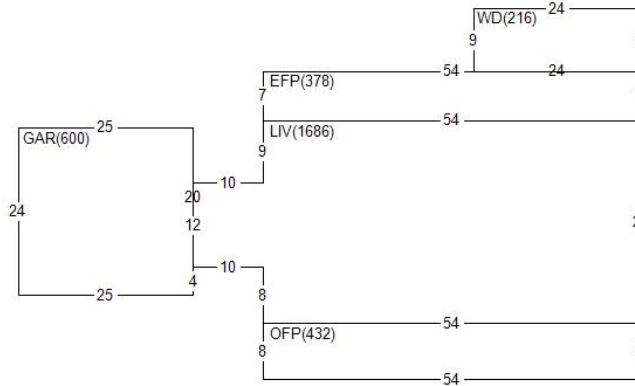

Land Value 26,760
 Misc Value 39,250
 Bldg Value 173,050
 Total Value 239,060
 Value By CAMA

RCN 211,039
 Pct Good 0.8200
 Obsol/Observed 0.0000
 Building Value 173,050

DOCUMENT #	DATE	QS	SALE PRICE
0994	U		8,573

PERMIT NO	TYPE	DATE	AMOUNT
R1-94-40	01	1094	

Appraiser KS K. Sondag
 Appr Date 07/06/22
 Use Code 0040 Imp Res
 NBHD 62000.10 VLMYR 1.0 STORY
 L100 M100 B144

AREA	FLAT	EFF% E/AREA	ACT% A/AREA	EA/AA	HEATED
OFP	810	1.00	810	1.00	810
CONDR	1475	1.00	1475	1.00	1475
BSMR	700	1.00	700	1.00	700
GAR	600	1.00	600	1.00	600
WD	216	1.00	216	1.00	216
EFP	378	1.00	378	1.00	378
LIV	1686	1.00	1686	1.00	1686

MISC BLDG CODE	DESC	LENGTH	WIDTH	UNITS	ADJ PRICE	EYB DT PCT	ADJUSTMENT	VALUE
1 1 OFP	Open Frame Porch	8.00	54.00	432.00	21.55	1995 A 18.00	1.00	7,630
2 1 OFP	Open Frame Porch	7.00	54.00	378.00	21.99	1995 A 18.00	1.00	6,820
3 1 WD	Wood Deck	9.00	24.00	216.00	19.35	1995 A 18.00	1.00	3,430
4 1 CONDR	Concrete Drivewa	59.00	25.00	1475.00	3.65	1995 A 18.00	1.00	4,420
6 1 DORM	Dormer	.00	.00	3.00	1850.00	1995 OD 0.00	1.00	5,550
7 1 EFP	Enclosed Fr. Por	54.00	7.00	378.00	36.79	1995 A 18.00	1.00	11,400
LAND LUSE DESC	ZONING	UNITS TP	PRICE	ADJUSTMENT CODE/FACTOR				VALUE
1 6200 VALMEYER	VR1	1.00 ST	26760.00	.00	.00	.00 TW	1.00	26,760