

LOT 270 NEW VALMEYER PHASE 5

VALMEYER IL 62295
Site Address: 000108 FOX POINTE

BLDG # 1
 Style/Stories 1.0 One Story
 Quality/Design C C-Average
 Building Use 0100 Single Fami
 Exterior Wall F Frame
 WALL % 100 100%
 Exterior Wall 1
 WALL 1% 000 N/A
 Crawl Sp. Adj C Crawl
 Slab Adjustment
 Basement
 Combination
 Attic Area
 Heat/AC Adj AC Central Air
 Comb Ht/AC Adj
 Fireplace
 Extra Fireplace 00 N/A
 Res Fixtures 0009 09 Fixtures
 Garage F Frame Garag
 Integral Garage
 Remodeling Adj 01 No Remodeli
 Actual Year Blt 2003
 Effect Year Blt 2003
 Cond/Desir/Util A Res CDU - A
 Township Multpl 06 TOWNSHIP #0
 Funct. Obs. %
 Economic Obs. %
 Observed Cond %
 Obs. Cond. Code
 Combination A
 Comb A Ht/AC
 Unfin Low/Level
 Full Basement F Full Baseme
 # Of Bedrooms 03 Three Bedro
 Sq.Ft.Grnd Area 1388

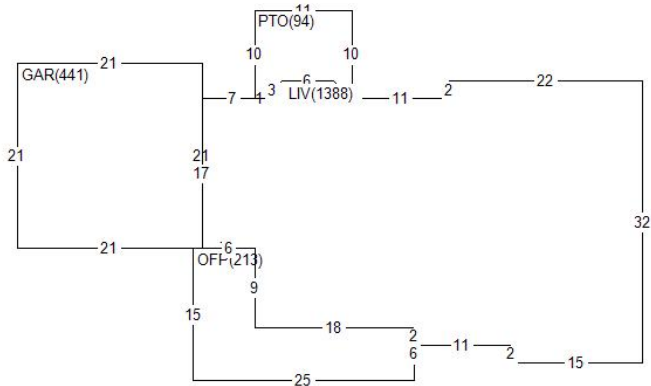

Land Value 26,760
 Misc Value 8,820
 Bldg Value 148,160
 Total Value 183,740
 Value By CAMA

RCN 166,468
 Pct Good 0.8900
 Obsol/Observed 0.0000
 Building Value 148,160

DOCUMENT #	DATE	QS	SALE PRICE
428039	0223	U	
364057	0413	Q	155,000
297432	0505	Q	175,000
PERMIT NO	TYPE	DATE	AMOUNT
R1-02-20	01	0702	

Appraiser AS A. Schwar
 Appr Date 03/08/23
 Use Code 0040 Imp Res
 NBHD 62000.10 VLMYR 1.0 STORY
 L100 M100 B144

AREA	FLAT	EFF%	E/AREA	ACT%	A/AREA	EA/AA	HEATED
OFF	213	1.00	213	1.00	213	213	
GAR	441	1.00	441	1.00	441	441	
PTO	94	1.00	94	1.00	94	94	
LIV	1388	1.00	1388	1.00	1388	1388	1388
CONDR	630	1.00	630	1.00	630	630	
CRWL	16	1.00	16	1.00	16	16	

MISC BLDG CODE	DESC	LENGTH	WIDTH	UNITS	ADJ PRICE	EYB DT	PCT	ADJUSTMENT	VALUE
1 1 PTO	Concrete Patio	.00	.00	94.00	3.65	2003 A	11.00	1.00	310
2 1 OFP	Open Frame Porch	.00	.00	213.00	23.02	2003 A	11.00	1.00	4,360
3 1 CONDR	Concrete Drivewa	30.00	21.00	630.00	3.65	2003 A	11.00	1.00	2,050
4 1 SHED	Frame Shed	10.00	8.00	80.00	26.74	2015 A	2.00	1.00	2,100

LAND LUSE DESC	ZONING	UNITS TP	PRICE	ADJUSTMENT	CODE/FACTOR	VALUE
1 6200 VALMEYER	VR1	1.00 ST	26760.00	.00	.00 TW 1.00	26,760